

Celik[®] *battery*

**Durable
Battery**



Automotive - Commercial - Leisure



**Durable
Battery**

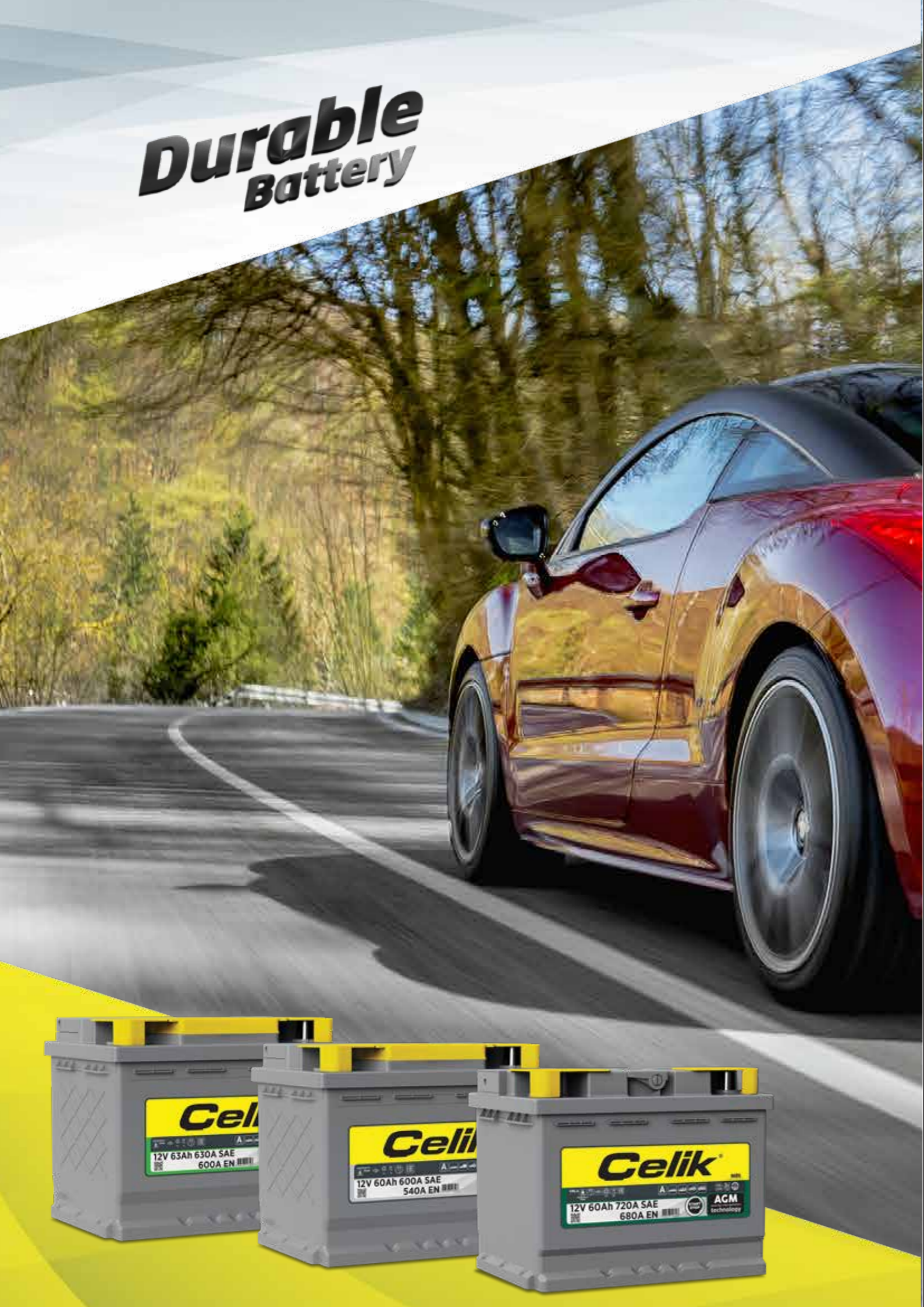

AUTOMOTIVE

Batteries for Cars and Light Commercial Vehicles



Superior Flooded Battery Technology

Çelik SFB type batteries are flooded type batteries featuring SLI technology, which are suitable for use in cars of all classes and light commercial vehicles. They meet the starter need of the vehicle and supply necessary energy when the engine is not running.

SFB type batteries are classified as Series 2 and Series 3 with different performance values to meet the electrical needs of vehicles.

series2

These are the products, which are designed to meet increasing electrical needs of the vehicles, with advanced technology and have a long service life.

series3

These are the products, which meet high performance and starter current needs of the vehicles under challenging climate conditions. They feature enhanced performance and have a long service life.

Superior Technical Features



Up to 25% higher performance than standard batteries



Higher performance under extreme climate conditions compared to standard batteries



Patented calcum (Ca) alloy grid technology



Sealed maintenance free safe lid technology

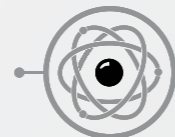

Advanced active material exclusively formulated for SFB technology



More vibration resistant compared to standard batteries

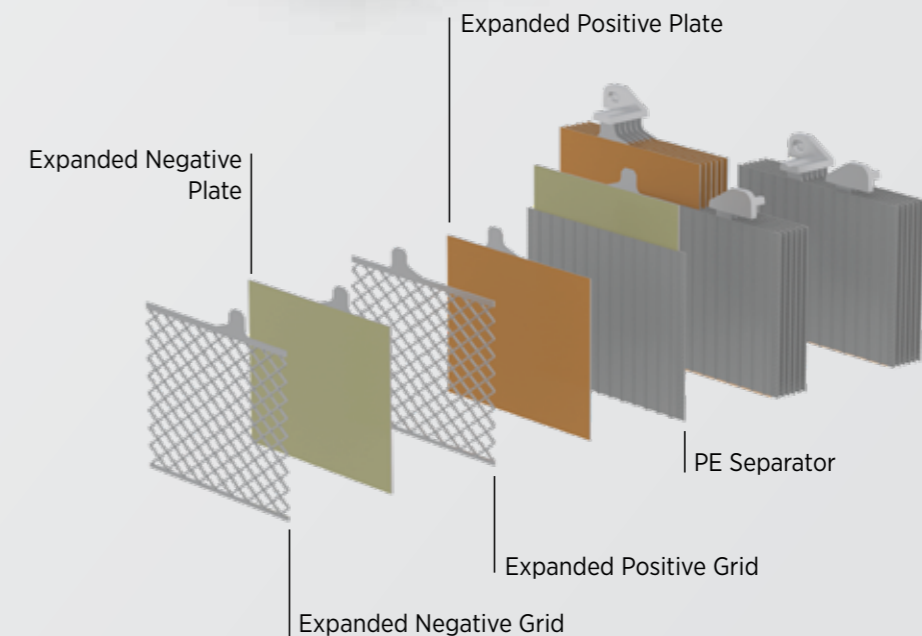
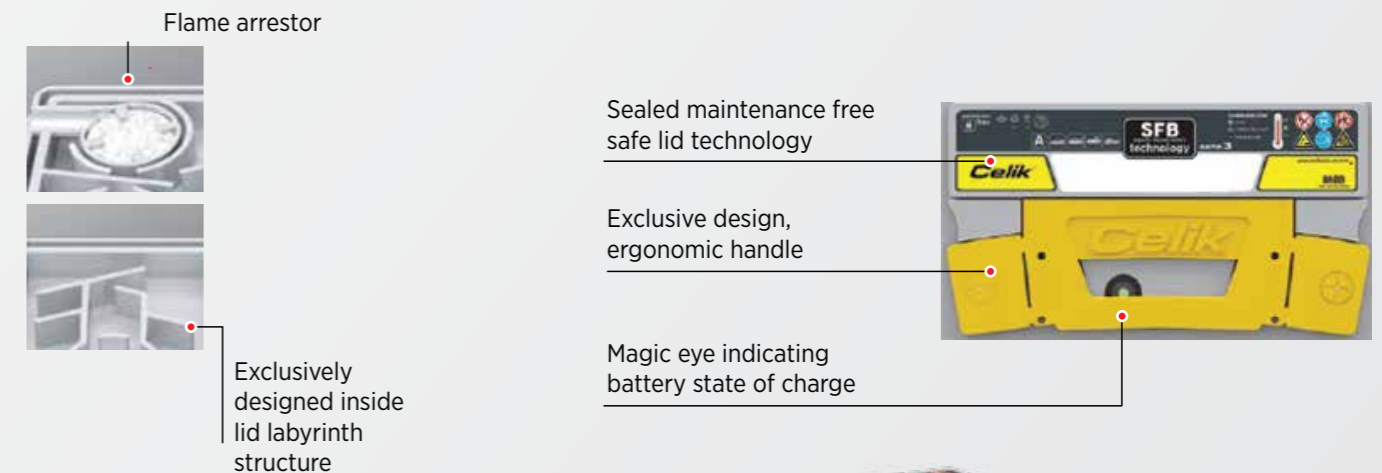



**START
STOP**

Start-Stop

Start-Stop technology that is designed to reduce fuel consumption and carbon dioxide emissions of vehicles, leads to an increase in the electrical needs of the vehicles. In these systems, batteries with high cycle life and high charging capacity are required to be used. Çelik Battery's product range offers different types of EFB and AGM batteries suitable for Start-Stop system.

EFB
Enhanced Flooded Battery
technology

AGM
Absorbent Glass Mat Battery
technology



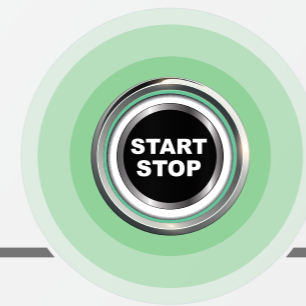

Enhanced Flooded Battery Technology

These are flooded type batteries developed for use in vehicles with Start-Stop technology. Thanks to their reinforced internal structure, they have 2 times longer cycle life and high charging characteristics compared to standard flooded type batteries. Çelik Battery EFB product line, which is also preferred by vehicle manufacturers, includes batteries suitable for European and Japanese vehicle models.

Superior Technical Features



Quick charge acceptance for Start-Stop technology

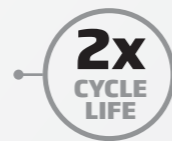

Up to 2 times longer cycle life

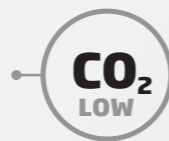

Innovative products for Start-Stop vehicles supporting reduced carbon dioxide emission

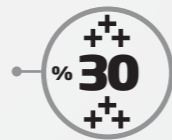

Up to 30% higher performance than standard batteries



Higher performance under extreme climate conditions compared to standard batteries

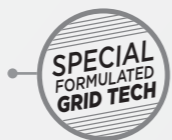

Patented calcium (Ca) alloy grid technology



Sealed maintenance free safe lid technology

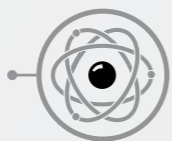

Advanced active material exclusively designed for micro-hybrid Start-Stop technology

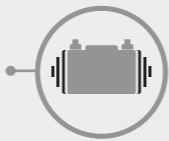

More vibration resistant compared to standard batteries

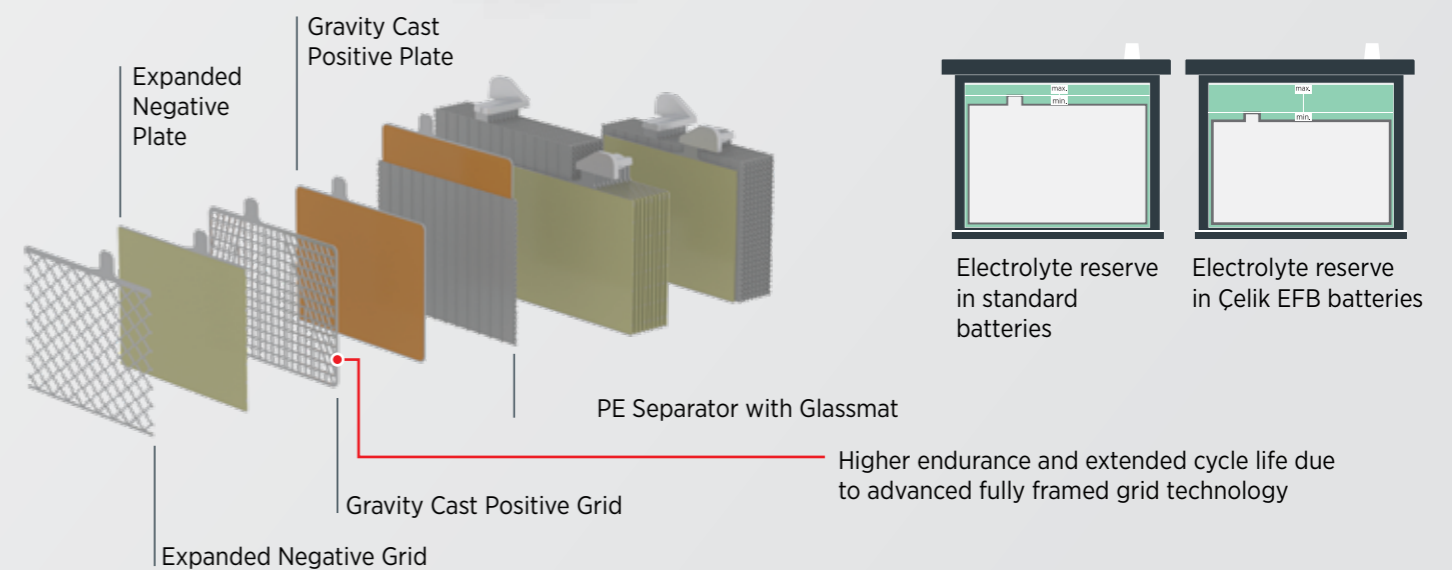
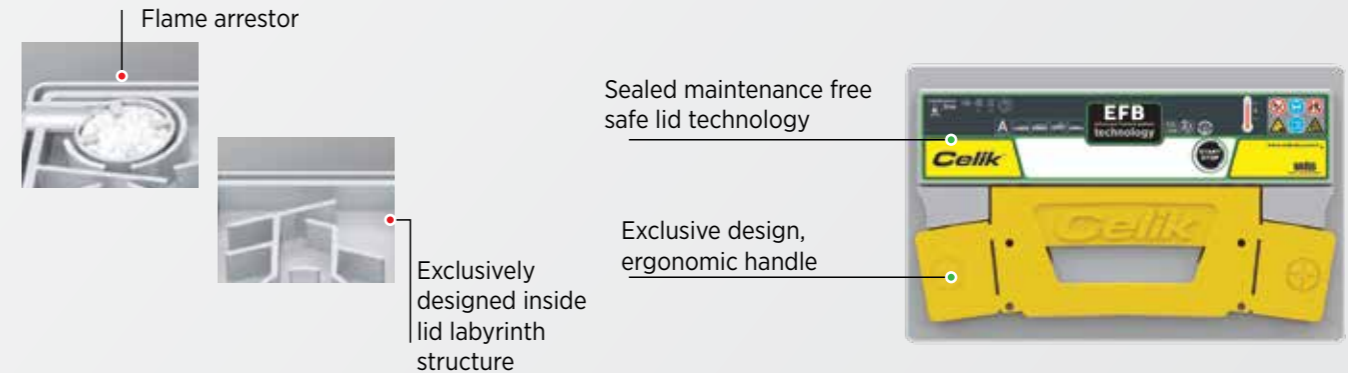

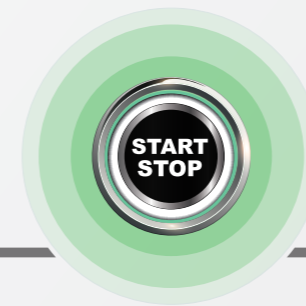

Absorbent Glass Mat Technology

These are VRLA type batteries developed with AGM technology, which are suitable for use in vehicles featuring advanced START-STOP technology with regenerative braking system. Thanks to the special internal structure design of AGM batteries and the VRLA technology, they have 3 times longer cycle life and high charging characteristics compared to flooded type batteries. Çelik Battery AGM product line, which is also preferred by vehicle manufacturers, includes batteries suitable for all types of vehicles.

Superior Technical Features



Quick charge acceptance for Start-Stop technology

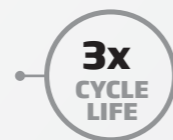

Up to 3 times longer cycle life

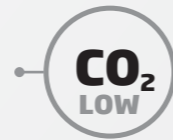

Innovative products for Start-Stop vehicles supporting reduced carbon dioxide emission

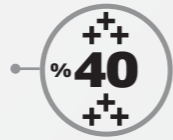

Up to 40% higher performance than standard batteries

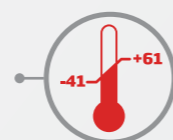

Higher performance under extreme climate conditions compared to standard batteries



Patented calcium (Ca) alloy grid technology



Sealed maintenance free safe lid technology

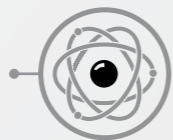

Advanced active material exclusively designed for AGM Start-Stop technology

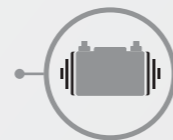

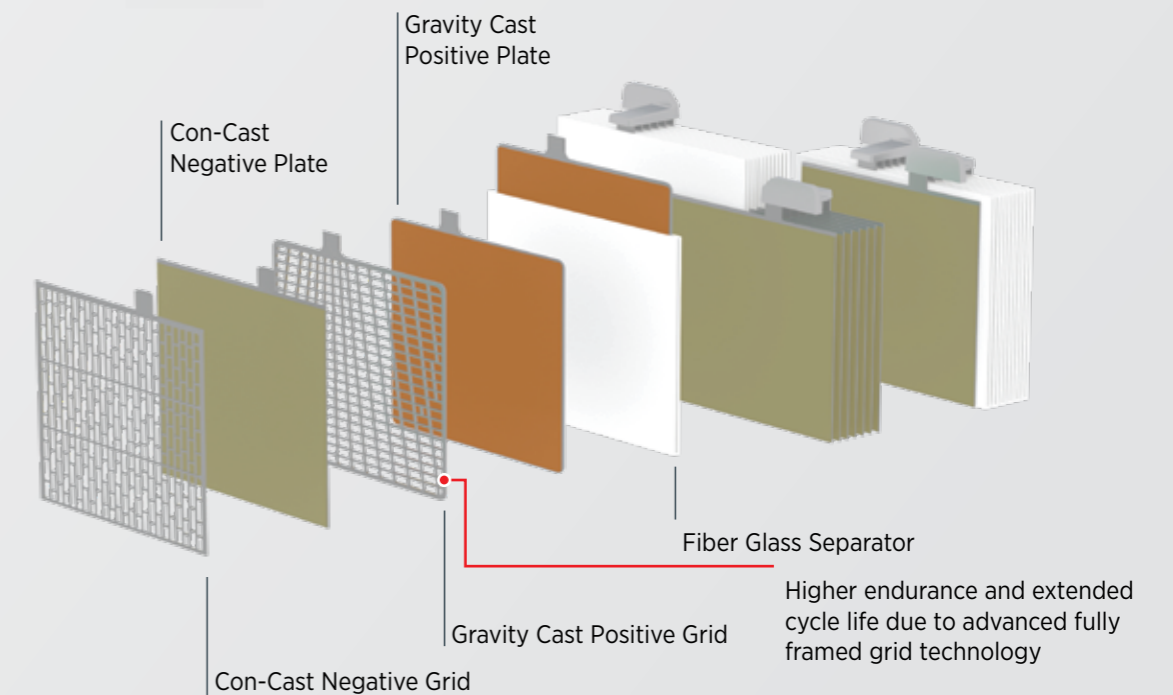

More vibration resistant compared to standard batteries



BATTERY REPLACEMENT CHART

REPLACED BATTERY OF THE VEHICLE

	Standard Battery	Start-Stop EFB Battery	Start-Stop AGM Battery
	✓	✗	✗
	✓	✓	✗
	✗	✗	✓



Replace with same technology battery



Replace with same technology battery

COMMERCIAL

Heavy and Super Heavy Duty Batteries

*EFB batteries are usually placed next to the engine, AGM batteries are placed inside the trunk or under the seat as they are affected by heat.



Commercial Batteries

Çelik Commercial batteries are flooded type batteries featuring EFB and SLI technology, which are suitable for use in commercial vehicles. They meet the starter need of the vehicle and supply necessary energy when the engine is not running. EFB batteries are high performance products developed for use in commercial vehicles featuring Start-Stop technology. SFB batteries, which are suitable for use in standard commercial vehicles, are classified as Series 1, Series 2 and Series 3 with Heavy Duty and Super Heavy Duty groups in order to meet the electrical needs of vehicles.





Enhanced Flooded Battery Technology

These are enhanced flooded type batteries, which are developed to meet the energy needs of commercial vehicles featuring Start-Stop technology. Thanks to their reinforced internal structure, they have 2 times longer cycle life and quick charging characteristics compared to standard flooded type batteries. They feature special lid technology offering high safety with central gas outlet system and flame arrestor features. Thanks to their high vibration resistance, they are maintenance-free, long-lasting batteries suitable for use in severe operating conditions.

EFB batteries can also be preferred in commercial vehicles with standard features for longer use and high performance.

Superior Technical Features



Quick charge acceptance for Start-Stop technology

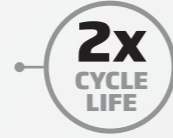

Up to 2 times longer cycle life

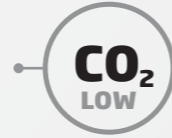

Innovative products for Start-Stop vehicles supporting reduced carbon dioxide emission

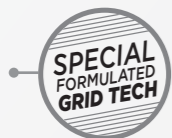

Patented, calcium (Ca) alloy grid technology developed for EFB commercial batteries

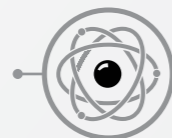

Active material developed for EFB commercial batteries

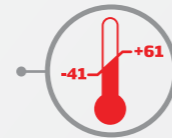

Higher performance under extreme climate conditions compared to standard batteries



Maintenance-free product technology



Shelf life up to 18 months under suitable conditions

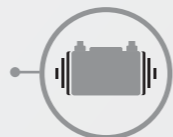

Meets V3 vibration resistance requirements according to EN 50342

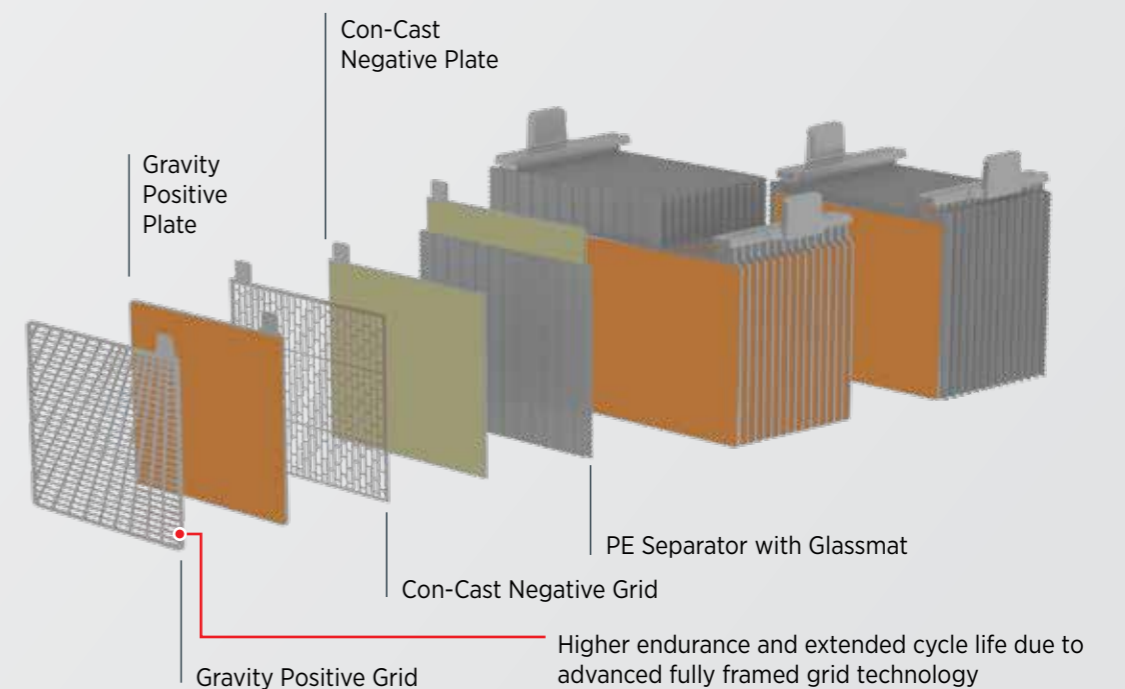
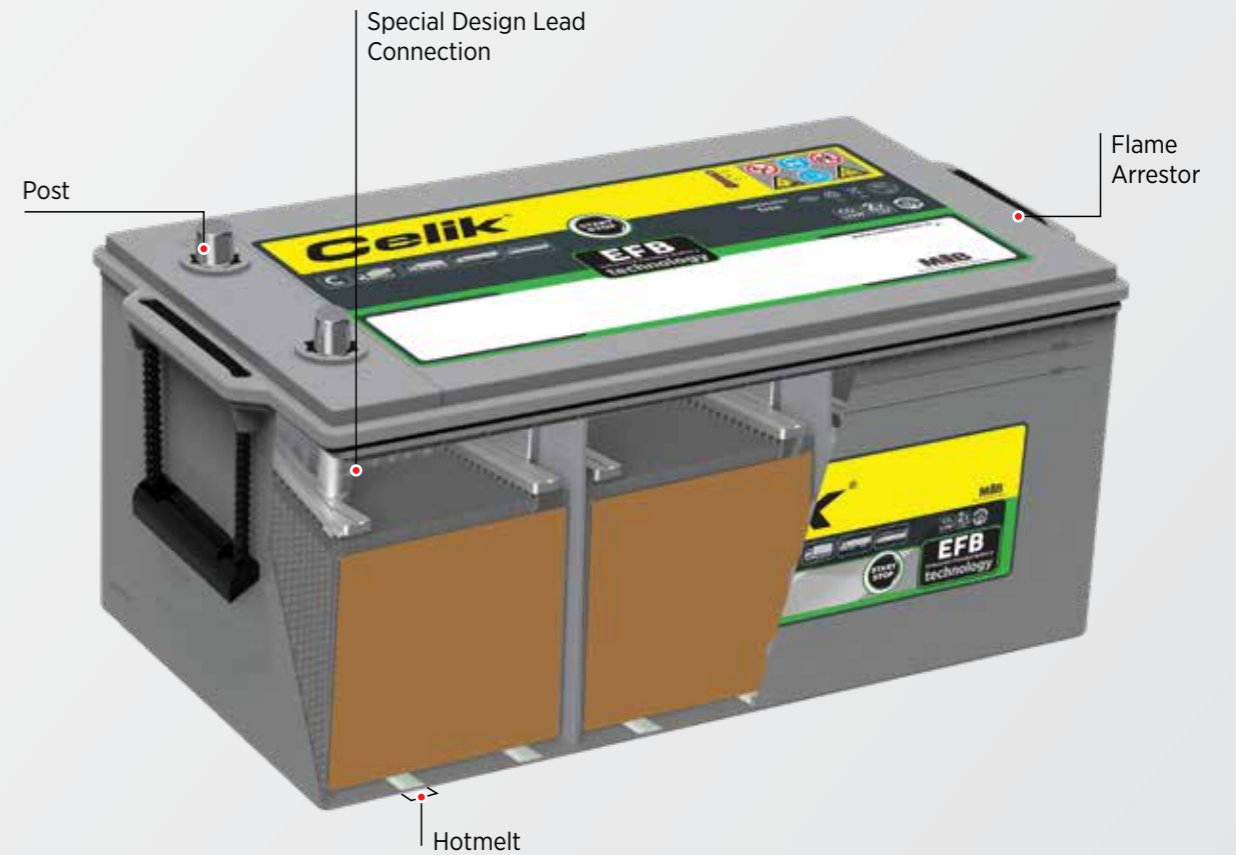



Superior Flooded Battery Technology series 1

These are flooded type batteries manufactured with SLI technology, which are developed to meet the energy needs of commercial and heavy commercial vehicles. They can be used in severe operating conditions thanks to its high vibration resistance. It is maintenance-free with its calcium (Ca) alloy grid structure and does not require extra maintenance service under suitable conditions. They are classified as Heavy Duty and Super Heavy Duty.

Superior Technical Features

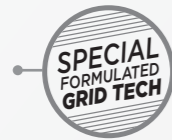

Advanced patented calcium (Ca) alloy grid technology exclusively designed for SFB Series 1 heavy and super heavy duty batteries

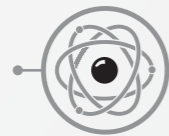

Advanced active material designed for SFB Series 1 heavy and super heavy duty commercial batteries



Higher performance under extreme climate conditions compared to standard batteries



Maintenance-free product technology



Shelf life up to 15 months under suitable conditions

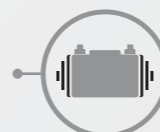

Meets V2 vibration resistance requirements according to EN 50342

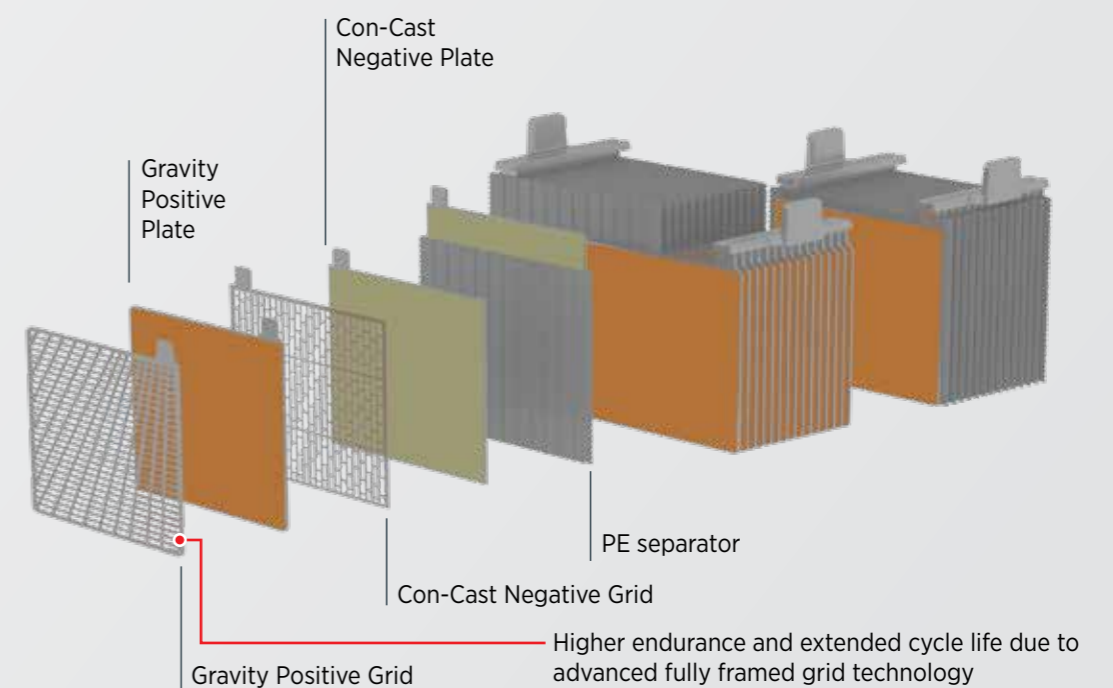
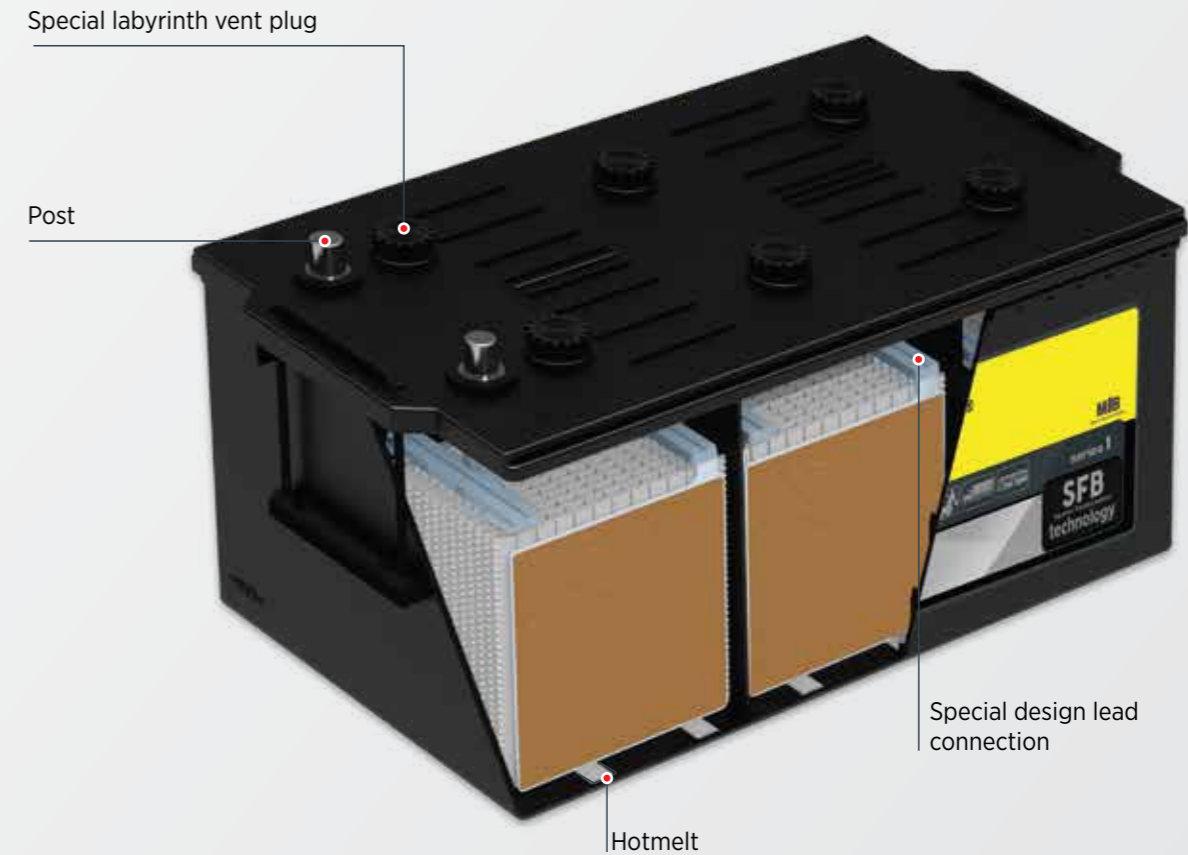



Superior Flooded Battery Technology series2

These are flooded type batteries manufactured with SLI technology, which are developed to meet the energy needs of commercial and heavy commercial vehicles. They can be used in severe operating conditions thanks to its high vibration resistance. It is maintenance-free with its calcium (Ca) alloy grid structure and does not require extra maintenance service under suitable conditions. These are heavy duty batteries featuring special lid technology offering high safety with central gas outlet system and flame arrestor.

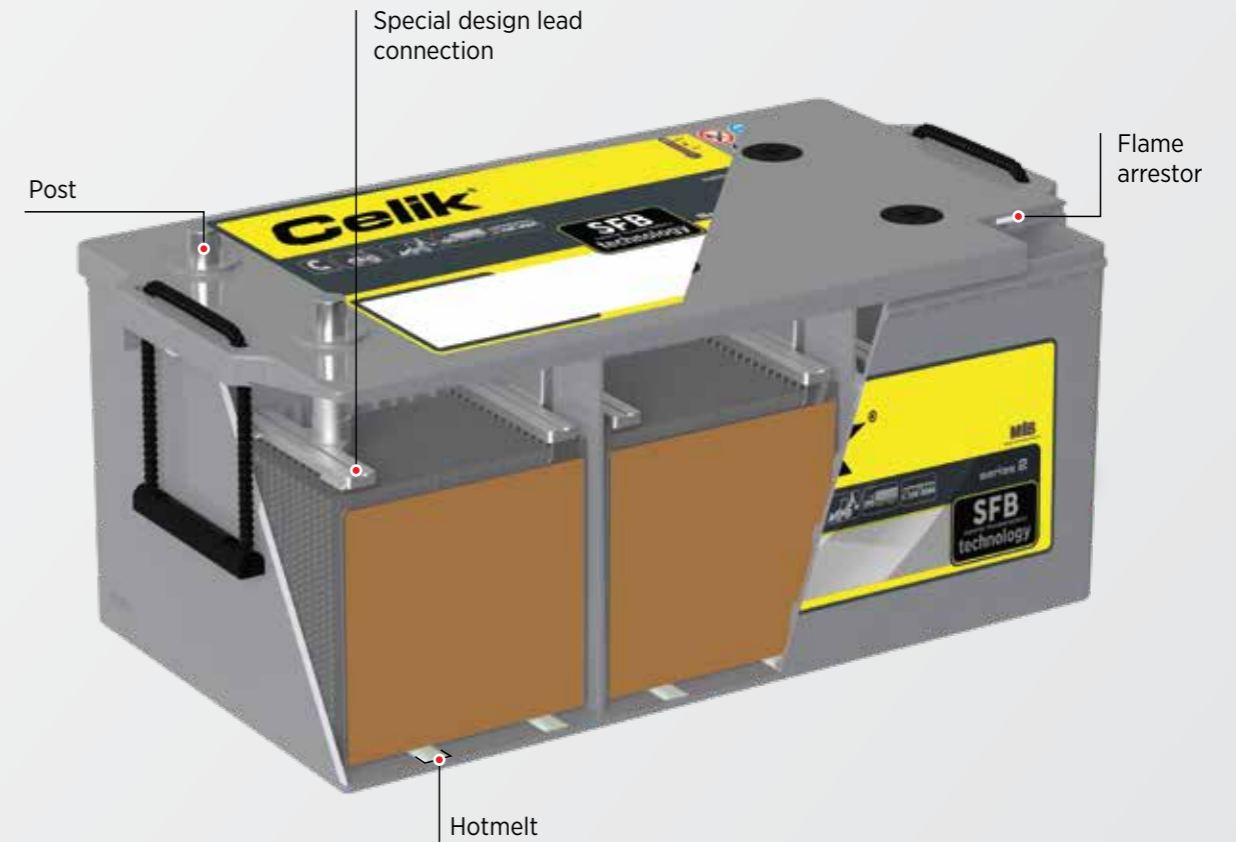

Superior Technical Features



Advanced patented calcium (Ca) alloy grid technology exclusively designed for SFB Series 2 heavy duty commercial batteries

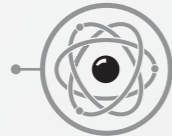

Advanced active material designed for SFB Series 2 heavy duty commercial batteries

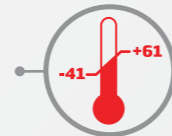

Higher performance under extreme climate conditions compared to standard batteries



Maintenance-free product technology



Shelf life up to 18 months under suitable conditions

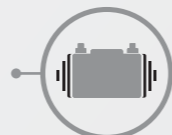

Meets V2 vibration resistance requirements according to EN 50342

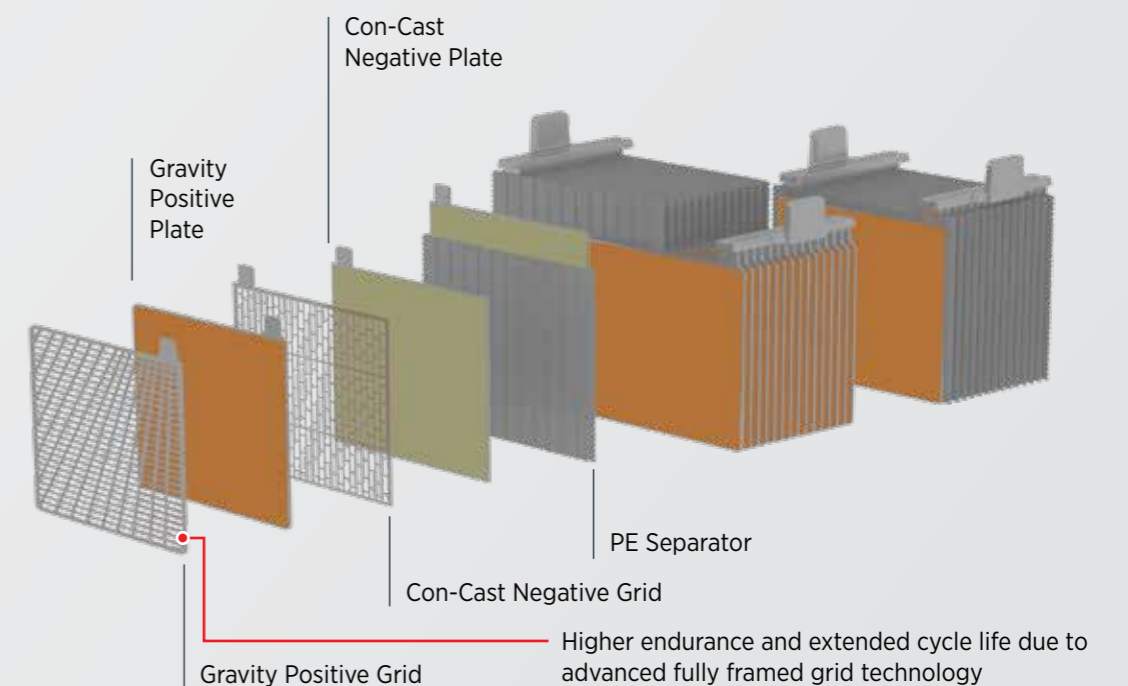



Üstün Özellikli Sulu Tip Akü Teknolojisi

series3

These are flooded type batteries manufactured with SLI technology, which are developed to meet the energy needs of commercial and heavy commercial vehicles. They can be used in severe operating conditions thanks to its high vibration resistance. It is maintenance-free with its calcium (Ca) alloy grid structure and does not require extra maintenance service under suitable conditions. These are Super Heavy Duty type batteries with long cycle life featuring special lid technology offering high safety with central gas outlet system and flame arrestor.

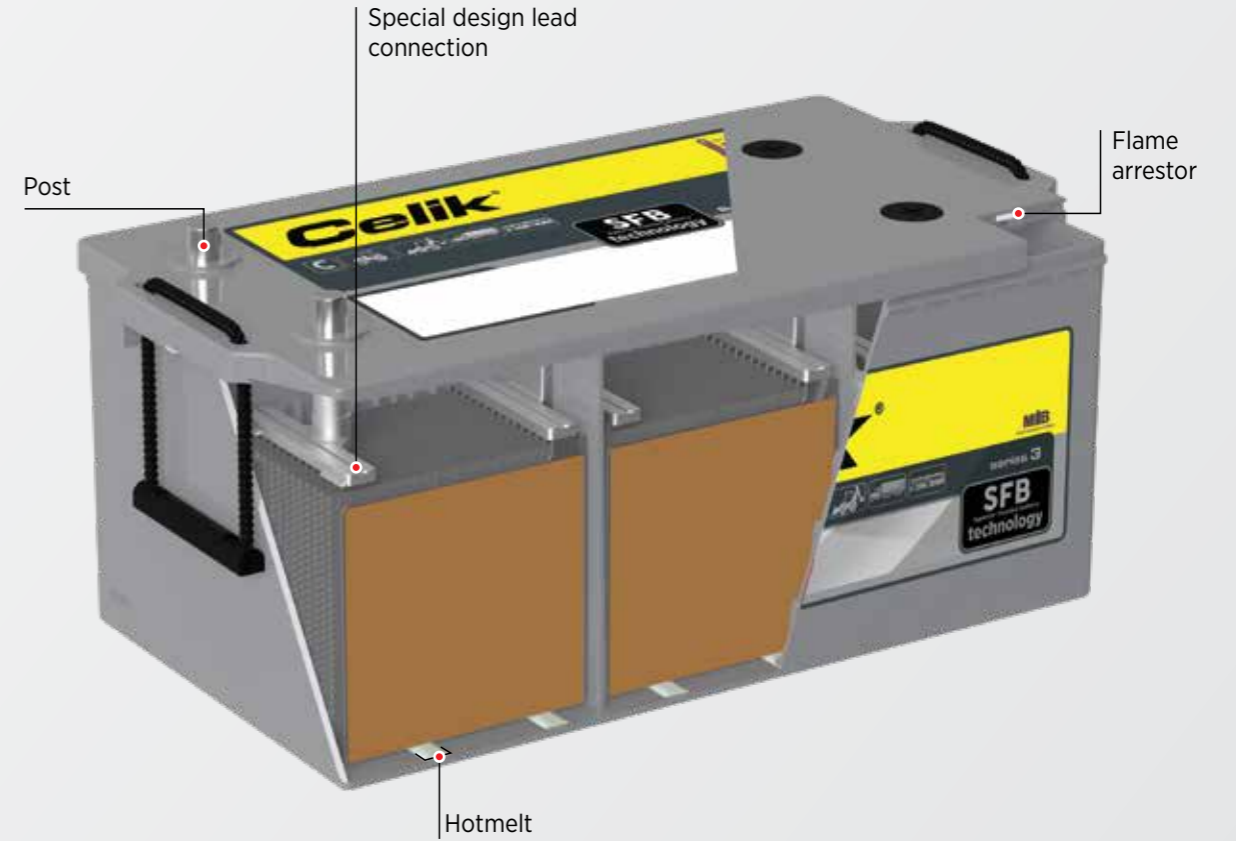

Superior Technical Features

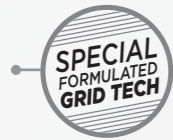

Advanced patented calcium (Ca) alloy grid technology exclusively designed for SFB Series 3 super heavy duty commercial batteries

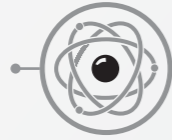

Advanced active material designed for SFB Series 3 super heavy duty commercial batteries

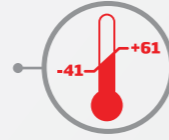

Higher performance under extreme climate conditions compared to standard batteries



Maintenance-free product technology



Shelf life up to 18 months under suitable conditions

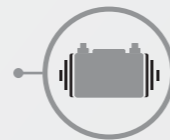

Meets V3 vibration resistance requirements according to EN 50342

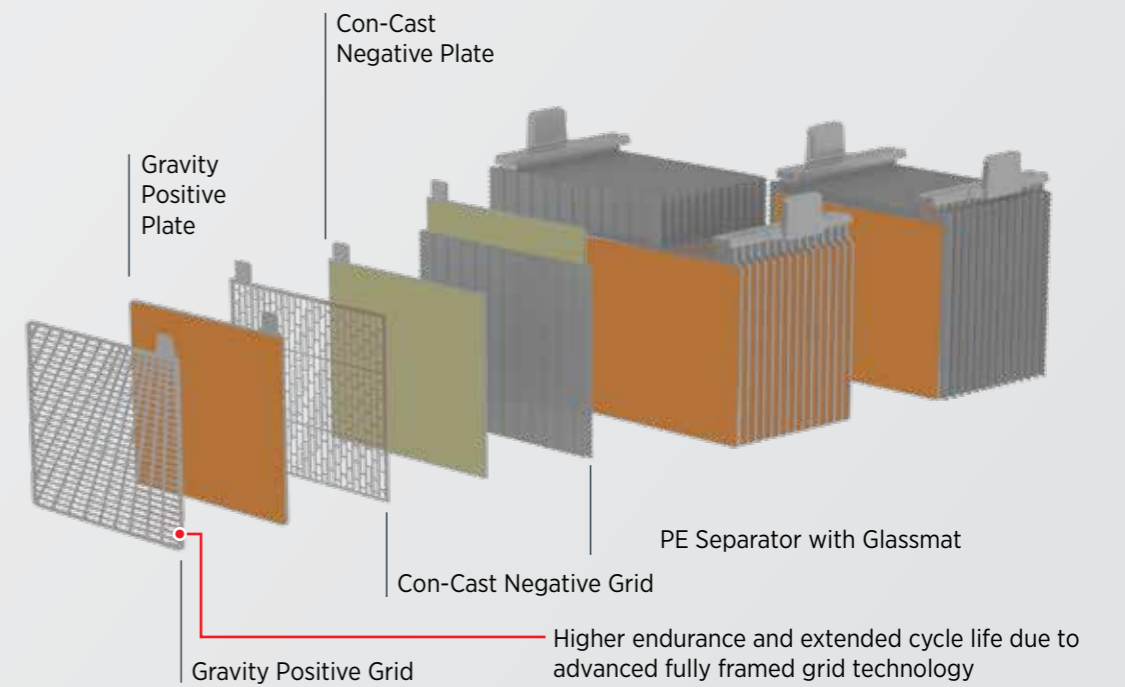

SFB



Taxi Batteries

Çelik SFB Taxi Batteries are enhanced flooded type batteries featuring SLI technology, which are suitable for use in commercial taxis. They meet the starter need of the vehicle and supply necessary energy when the engine is not running. These types of batteries are designed with a high cycle life as they are used more than standard batteries.



SFB

Standard Military Purposes Batteries

SFB Type Military Batteries are flooded type batteries comply to NATO VG95928 standard.

It is suitable for use in extreme climate conditions thanks to its high starting power, reinforced internal structure and impact resistance. It is safe with its special box design made of flame retardant plastic material.



AGM

AGM Military Purposes Batteries

AGM Type Military Batteries are products with VRLA technology, which comply with Nato MIL-STD-810G standards.

It is suitable for use in extreme climate conditions thanks to its high starting power, reinforced internal structure and impact resistance. It is safe with its special box design made of flame retardant plastic material. It is resistant to very high currents thanks to its specially designed brass terminals which are different from standard batteries.



LEISURE

Leisure and Alternative Energy Batteries



Superior Flooded Battery Technology - Marine

Marine Batteries are produced with SLI technology to meet the energy needs of water transportation vehicles. They offer high safety with special lid technology featuring a central gas outlet system and flame arrestor. They offer a longer cycle life than standard batteries thanks to the improved grid alloy, active material and special fiber separators.

Çelik Marine Batteries are made of flame retardant plastic material and have Turkish Loyd certificate.

Superior Technical Features



Advanced patented calcium (Ca) alloy grid technology exclusively designed for SFB marine batteries

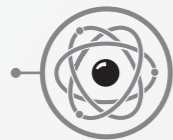

Advanced active material developed for SFB marine batteries



Spill proof electrolyte system up to 55° tilt angle

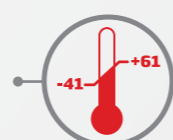

Higher performance under extreme climate conditions compared to standard batteries



Maintenance-free product technology

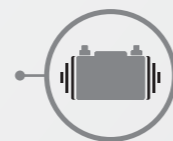

More vibration resistant

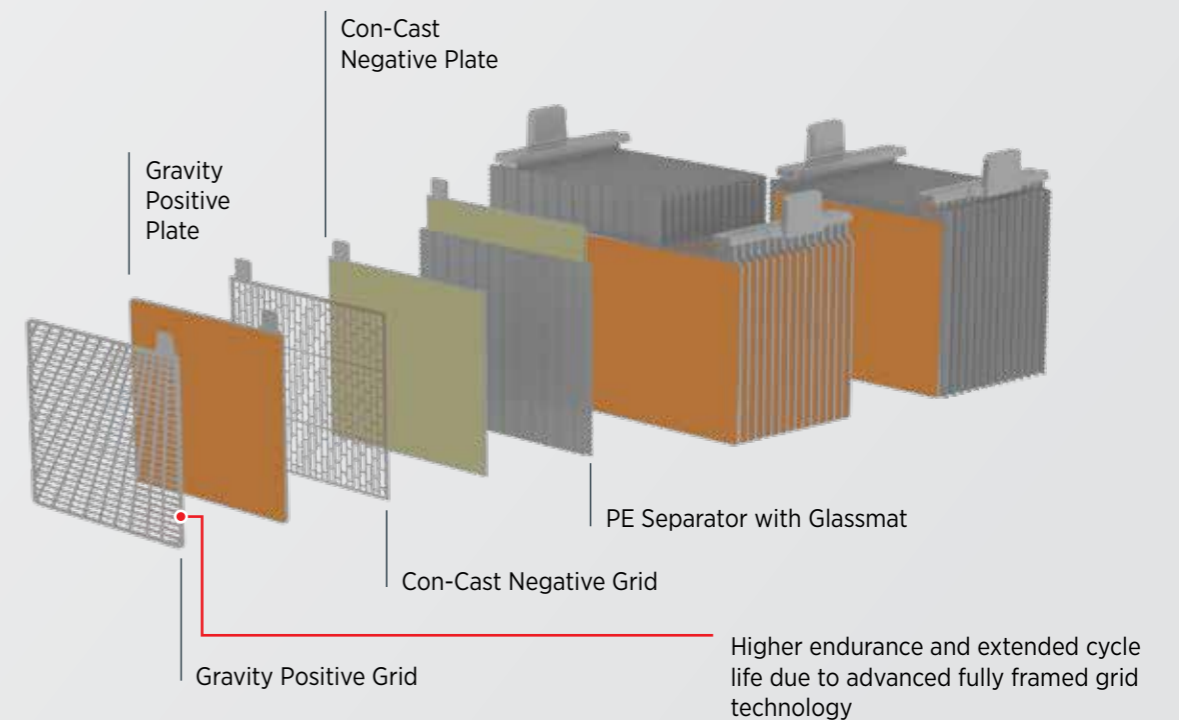
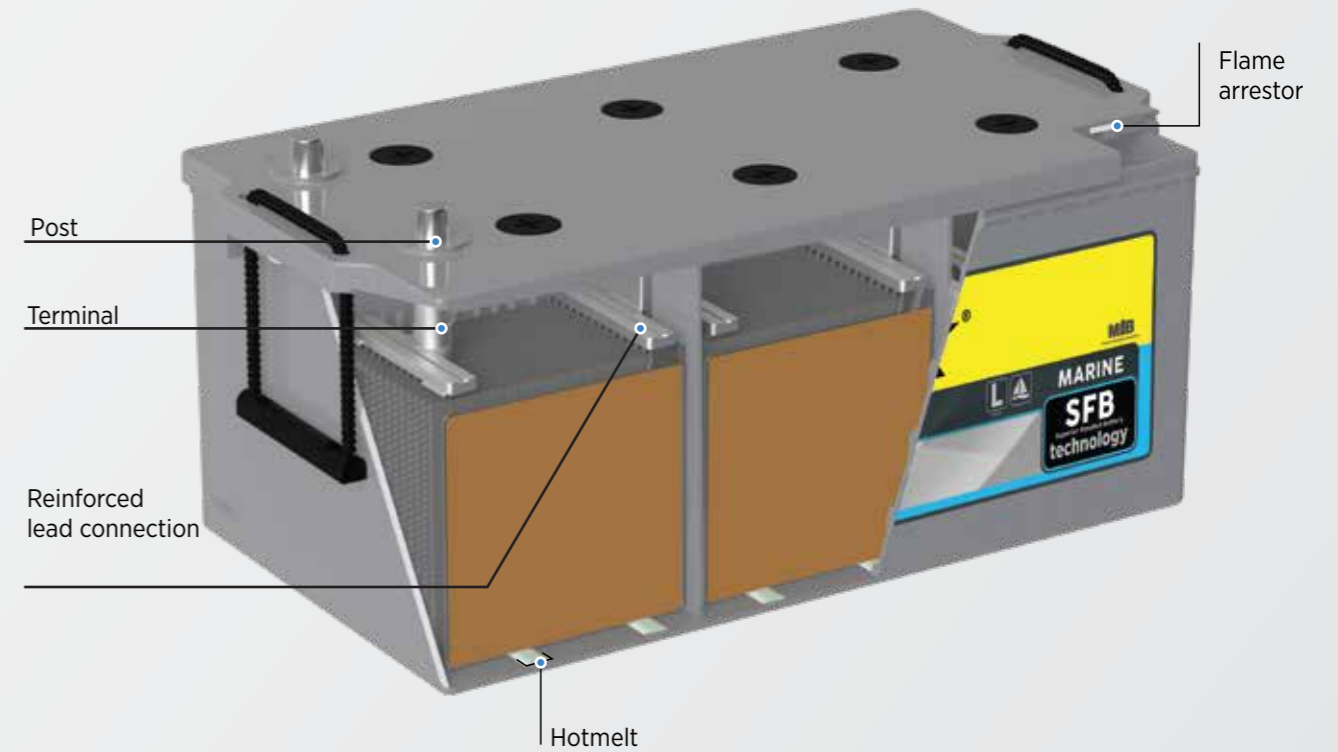

Enhanced Flooded Battery Technology - Full Energy

Full Energy and Solar batteries are the products designed to be used in energy storage solutions, with an advanced internal structure with high cycle life. They are capable of deep cycling up to 50% in high energy consuming applications. They are maintenance-free thanks to calcium (Ca) alloy grid technology. They are suitable for use in cleaning machines, alarm and emergency systems, wheelchairs, lifts, pallet trucks, golf carts and caravans.

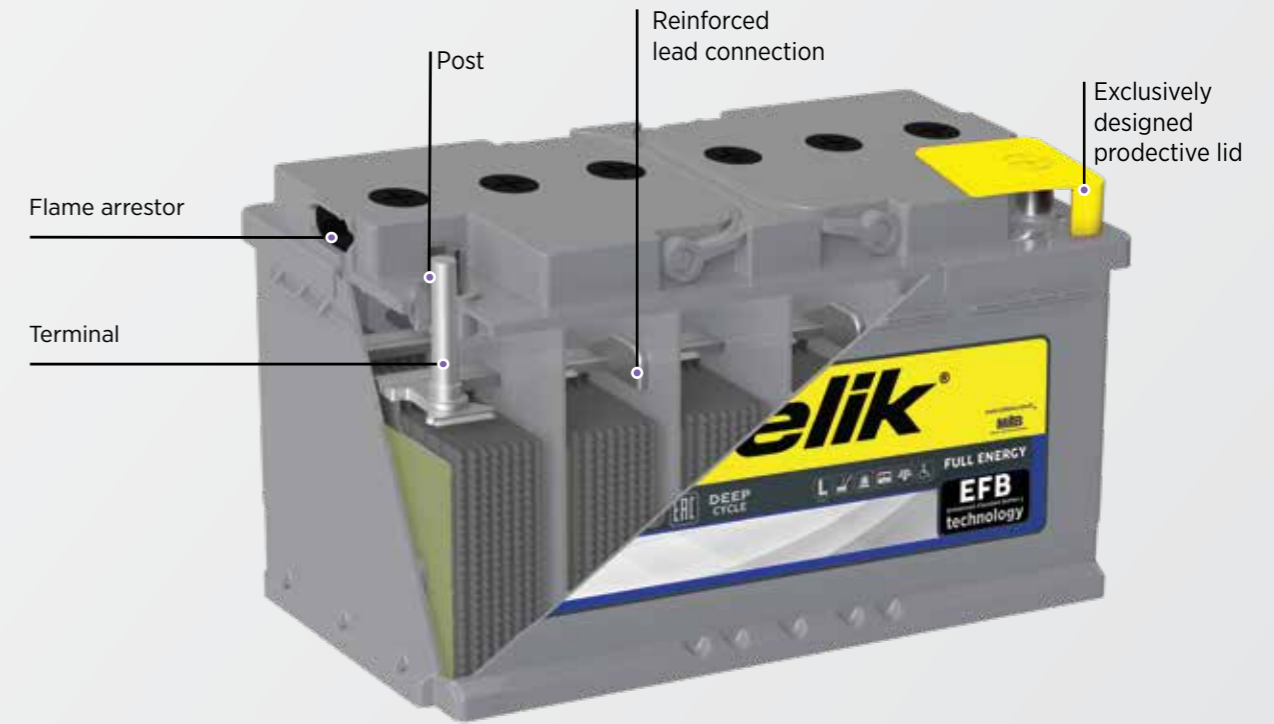

Superior Technical Features

Advanced patented calcium (Ca) alloy grid technology exclusively designed for EFB batteries

Advanced active material developed for EFB batteries

Higher performance under extreme climate conditions compared to standard batteries

Resistant to deep discharge

Maintenance-free product technology

More vibration resistant

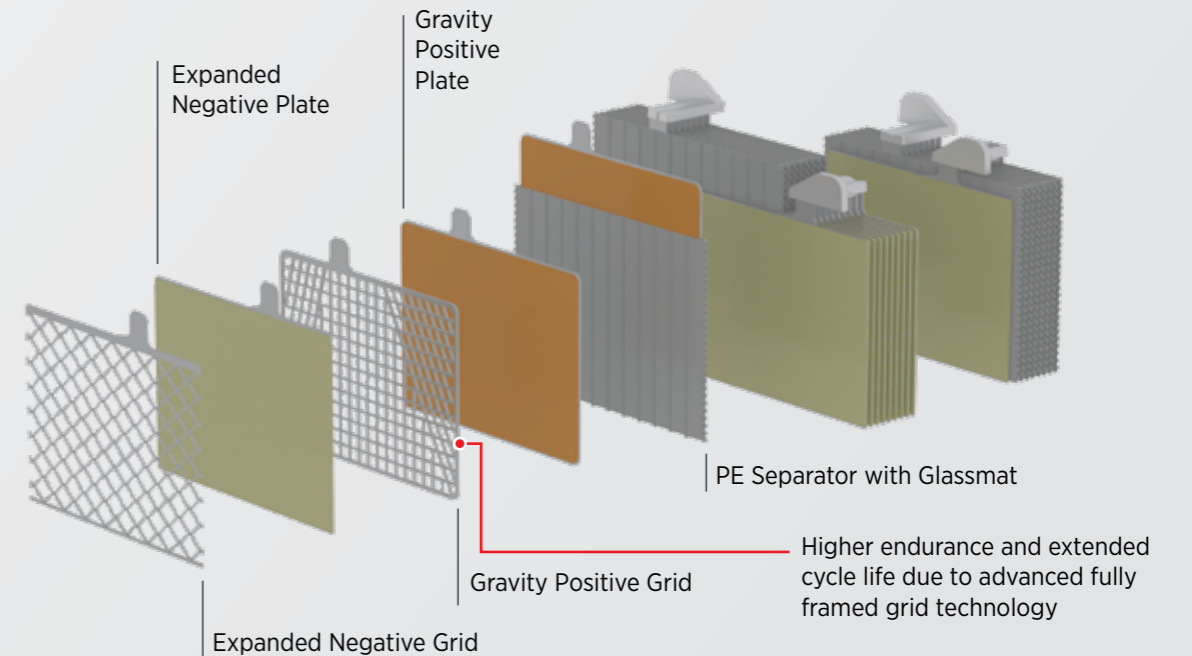

Valve Regulated Lead Acid Technology - GEL

Çelik GEL Batteries are the products designed to be used in energy storage solutions, which have the longest cycle life among lead-acid batteries. The electrolyte in the battery is in the gel form instead of liquid. Thanks to the VRLA technology, there is no gas release while using the battery and therefore it is suitable for indoor usage. Minimum discharging feature provides maximum shelf life under suitable storage conditions.

Superior Technical Features

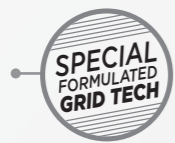

Advanced patented calcium (Ca) alloy grid technology exclusively designed for GEL batteries

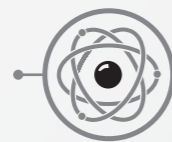

Advanced active material developed for GEL batteries



Higher performance under extreme climate conditions compared to standard batteries



Maintenance-free product technology



Exclusively designed valve system with pressure control (VRLA)

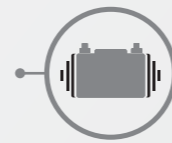

More vibration resistant



Spill proof gel electrolytes



Resistant to deep discharge

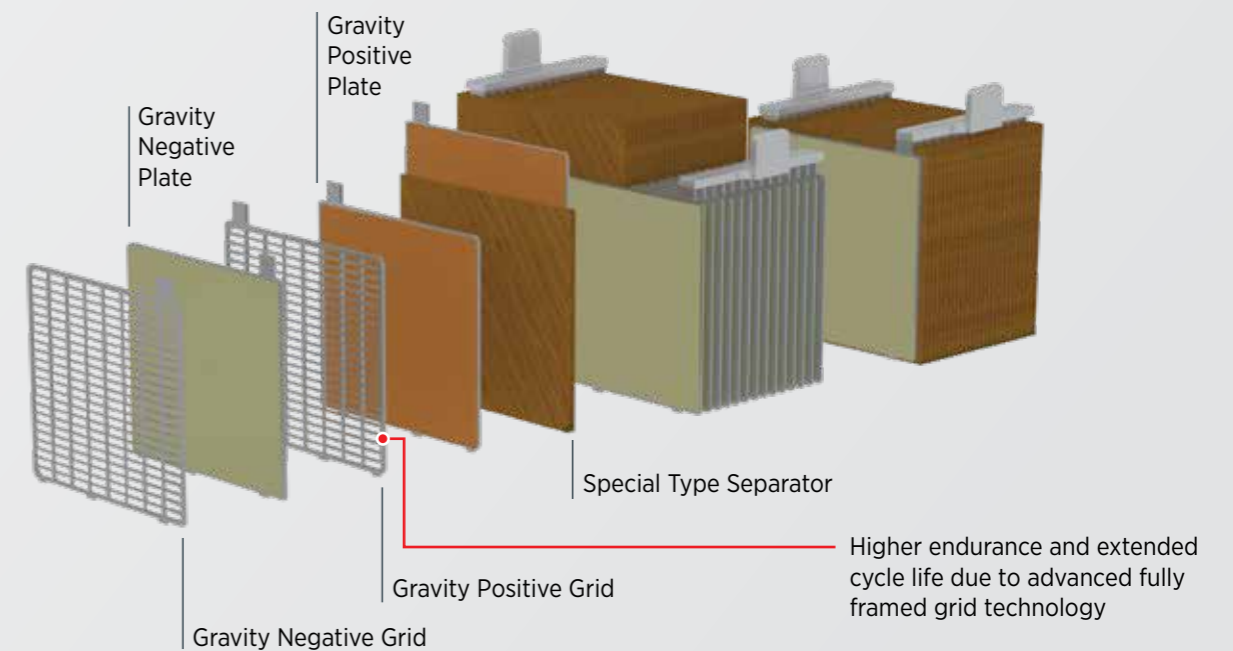
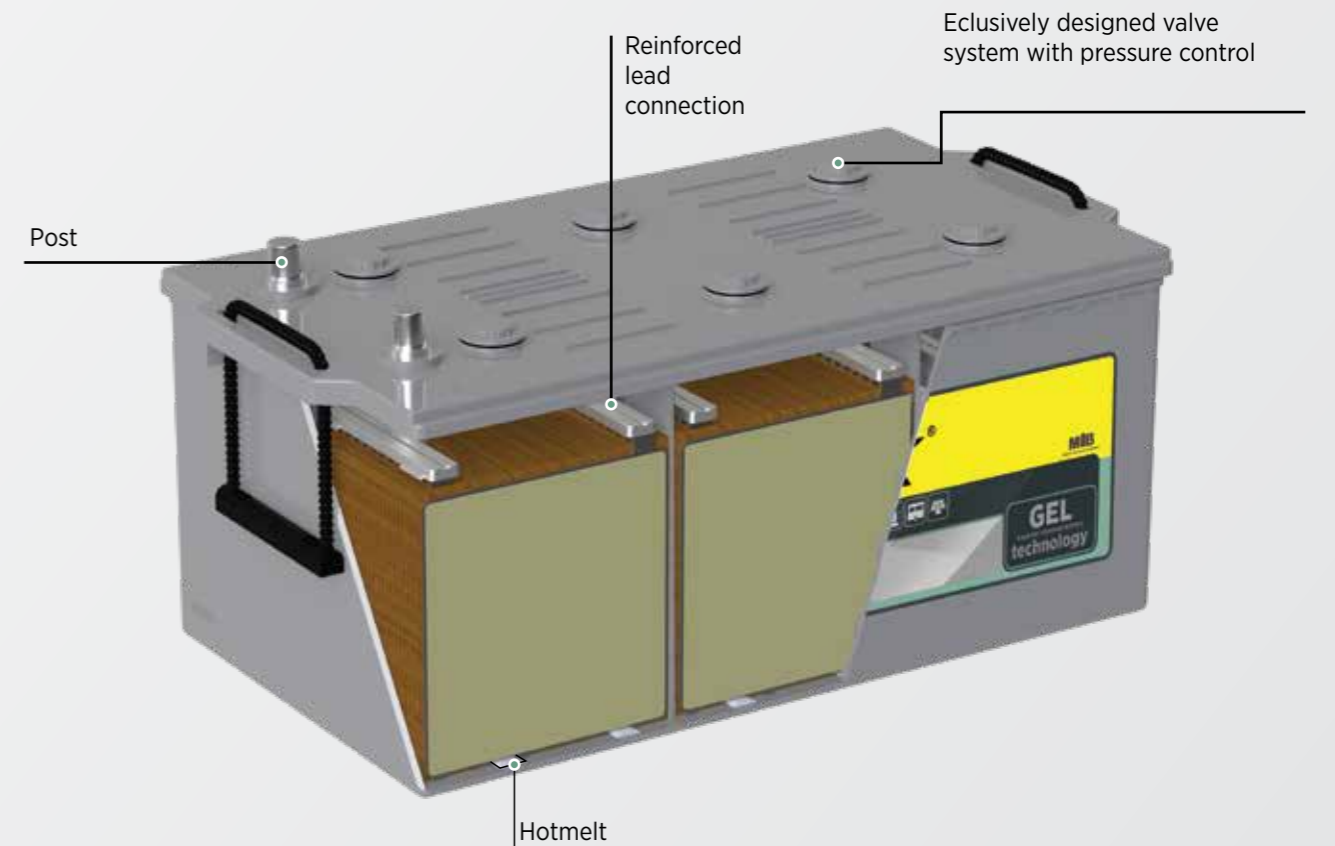

**Durable
Battery**



Product List

AUTOMOTIVE

AUTOMOTIVE

SFB SERIES 2 - JAPANESE (JIS) TYPE STARTER BATTERIES

Box	Celik Code	Part Number	Capacity at 20 Hr Rate (Ah)	CCA EN (A)	CCA SAE (A)	Layout	Terminal	Hold Down	Lenght (mm)	Width (mm)	Height Except Terminal (mm)	Height (mm)	Weight With Acid (kg)
B20 (NS40)	B20.35.024.G	40B19FL	35	240	260	0	3	B01	196	134	202	222	9.4
	B20.35.024.H	40B19FR	35	240	260	1	3	B01	196	134	202	222	9.4
	B20.35.028.G	40B19FL	35	280	300	0	3	B01	196	134	202	222	9.6
	B20.35.028.H	40B19FR	35	280	300	1	3	B01	196	134	202	222	9.6
	B20.40.033.G	40B19FL	40	330	300	0	3	B01	196	134	202	222	10.2
	B20.40.033.H	40B19FR	40	330	350	1	3	B01	196	134	202	222	10.2
B24 (NS60)	B24.42.030.A	45B24LS	42	300	320	0	1	B00	237	127	201	222	11.5
	B24.42.030.B	45B24RS	42	300	320	1	1	B00	237	127	201	222	11.5
	B24.45.030.A	50B24LS	45	300	320	0	1	B00	237	127	201	222	11.6
	B24.45.030.B	50B24RS	45	300	320	1	1	B00	237	127	201	222	11.6
	B24.45.030.E	50B24L	45	300	320	0	3	B00	237	127	201	222	11.6
	B24.45.030.F	50B24R	45	300	320	1	3	B00	237	127	201	222	11.6
	B24.45.036.A	50B24LS	45	360	400	0	1	B00	237	127	201	222	12.1
	B24.45.036.B	50B24RS	45	360	400	1	1	B00	237	127	201	222	12.1
	B24.45.036.E	50B24L	45	360	400	0	3	B00	237	127	201	222	12.1
	B24.45.036.F	50B24R	45	360	400	1	3	B00	237	127	201	222	12.1
D20	D20.50.042.C	50D20FL	50	420	450	0	1	B01	203	175	183	202	12.0
	D20.50.042.D	50D20FR	50	420	450	1	1	B01	203	175	183	202	12.0
D23	D23.60.045.A	55D23L	60	450	480	0	1	B00	232	173	204	225	15.0
	D23.60.045.B	55D23R	60	450	480	1	1	B00	232	173	204	225	15.0
	D23.60.045.C	55D23FL	60	450	480	0	1	B01	232	173	204	225	15.0
	D23.60.045.D	55D23FR	60	450	480	1	1	B01	232	173	204	225	15.0
	D23.60.052.A	55D23L	60	520	550	0	1	B00	232	173	204	225	15.5
	D23.60.052.B	55D23R	60	520	550	1	1	B00	232	173	204	225	15.5
	D23.60.052.C	55D23FL	60	520	550	0	1	B01	232	173	204	225	15.5
	D23.60.052.D	55D23FR	60	520	550	1	1	B01	232	173	204	225	15.5
D26 (N50)	D26.70.054.A	80D26L	70	540	600	0	1	B00	260	173	204	225	17.0
	D26.70.054.B	80D26R	70	540	600	1	1	B00	260	173	204	225	17.0
	D26.70.054.C	80D26FL	70	540	600	0	1	B01	260	173	204	225	17.0
	D26.70.054.D	80D26FR	70	540	600	1	1	B01	260	173	204	225	17.0
	D26.70.063.A	80D26L	70	630	680	0	1	B00	260	173	204	225	17.4
	D26.70.063.B	80D26R	70	630	680	1	1	B00	260	173	204	225	17.4
	D26.70.063.C	80D26FL	70	630	680	0	1	B01	260	173	204	225	17.4
	D26.70.063.D	80D26FR	70	630	680	1	1	B01	260	173	204	225	17.4
D31 (N70)	D31.70.053.C	80D31FL	70	530	550	0	1	B01	306	175	202	224	20.0
	D31.70.053.D	80D31FR	70	530	550	1	1	B01	306	175	202	224	20.0
	D31.80.067.C	95D31FL	80	670	720	0	1	B01	306	175	202	224	20.5
	D31.80.067.D	95D31FR	80	670	720	1	1	B01	306	175	202	224	20.5
	D31.90.066.C	105D31FL	90	660	720	0	1	B01	306	175	202	224	22.0
	D31.90.066.D	105D31FR	90	660	720	1	1	B01	306	175	202	224	22.0
	D31.90.072.C	105D31FL	90	720	750	0	1	B01	306	175	202	224	22.4
	D31.90.072.D	105D31FR	90	720	750	1	1	B01	306	175	202	224	22.4
	D31.100.076.C	115D31FL	100	760	800	0	1	B01	306	175	202	224	23.5
	D31.100.076.D	115D31FR	100	760	800	1	1	B01	306	175	202	224	23.5

SFB SERIES 3 - JAPANESE (JIS) TYPE STARTER BATTERIES

Box	Celik Code	Part Number	Capacity at 20 Hr Rate (Ah)	CCA EN (A)	CCA SAE (A)	Layout	Terminal	Hold Down	Lenght (mm)	Width (mm)	Height Except Terminal (mm)	Height (mm)	Weight With Acid (kg)
B20 (NS40)	B20.42.035.E	42B19L	42	350	390	0	3	B00	196	134	202	222	10.3
	B20.42.035.F	42B19R	42	350	390	1	3	B00	196	134	202	222	10.3
	B20.42.035.G	42B19FL	42	350	390	0	3	B01	196	134	202	222	10.3
	B20.42.035.H	42B19FR	42	350	390	1	3	B01	196	134	202	222	10.3
B24 (NS60)	B24.55.045.A	55B24LS	55	450	480	0	1	B00	237	127	201	222	13.2
	B24.55.045.B	55B24RS	55	450	480	1	1	B00	237	127	201	222	13.2
	B24.55.045.E	55B24L	55	450	480	0	3	B00	237	127	201	222	13.2
D20	D20.55.045.C	55D20FL	55	450	480	0	1	B01	203	175	183	202	12.6
	D20.55.045.D	55D20FR	55	450	480	1	1	B01	203	175	183	202	12.6
D23	D23.68.060.A	70D23L	68	600	650	0	1	B00	232	173	204	225	16.25
	D23.68.060.B	70D23R	68	600	650	1	1	B00	232	173	204	225	16.25
	D23.68.060.C	70D23FL	68	600	650	0	1	B01	232	173	204	225	16.25
	D23.68.060.D	70D23FR	68	600	650	1	1	B01	232	173	204	225	16.25
D26 (N50)	D26.75.064.A	80D26L	75	640	680	0	1	B00	260	173	204	225	17.8
	D26.75.064.B	80D26R	75	640	680	1	1	B00	260	173	204	225	17.8
	D26.75.064.C	80D26FL	75	640	680	0	1	B01	260	173	204	225	17.8
	D26.75.064.D	80D26FR	75	640	680	1	1	B01	260	173	204	225	17.8
	D26.80.066.A	95D26L	80	660	720	0	1	B00	260	173	204	225	19.0
	D26.80.066.B	95D26R	80	660	720	1	1	B00	260	173	204	225	19.0
	D26.80.066.C	95D26FL	80	660	720	0	1	B01	260	173	204	225	19.0
D31 (N70)	D31.100.085.C	115D31FL	100	850	900	0	1	B01	306	175	202	224	24.0
	D31.100.085.D	115D31FR	100	850	900	1	1	B01	306	175	202	224	24.0

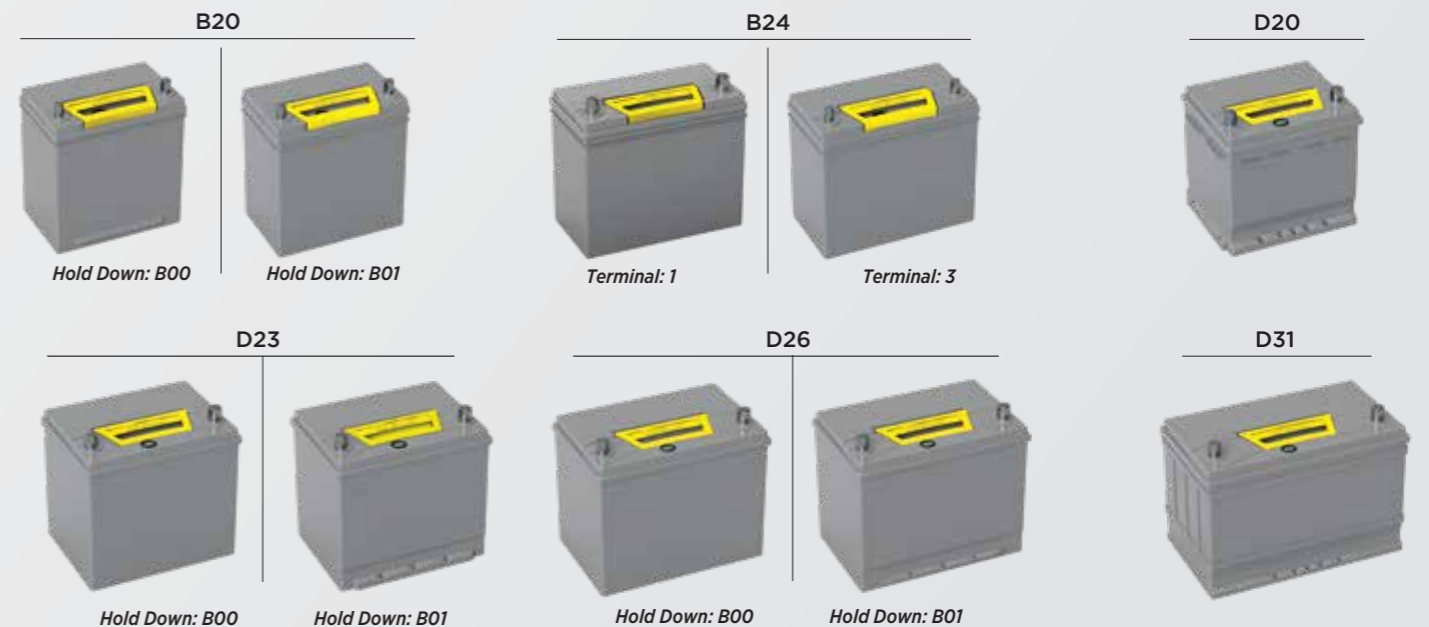

AUTOMOTIVE

EFB - JAPANESE (JIS) TYPE STARTER BATTERIES

Box	Çelik Code	Part Number	Capacity at 20 Hr Rate (Ah)	CCA EN (A)	CCA SAE (A)	Layout	Terminal	Hold Down	Lenght (mm)	Width (mm)	Height Except Terminal (mm)	Height (mm)	Weight With Acid (kg)
B24	EFB.B24.45.036.A	-	45	360	400	0	1	B00	237	127	201	222	13.5
B24	EFB.B24.45.036.E	-	45	360	400	0	3	B00	237	127	201	222	13.5
D23	EFB.D23.64.062.C	-	64	620	650	0	1	B01	232	173	204	225	16.5
D26	EFB.D26.72.076.C	-	72	760	800	0	1	B01	260	173	204	225	18.4
D31	EFB.D31.86.080.C	-	86	800	850	0	1	B01	306	175	202	224	21.7

EFB - EUROPEAN (DIN) TYPE STARTER BATTERIES

Box	Çelik Code	Part Number	Capacity at 20 Hr Rate (Ah)	CCA EN (A)	CCA SAE (A)	Layout	Terminal	Hold Down	Lenght (mm)	Width (mm)	Height Except Terminal (mm)	Height (mm)	Weight With Acid (kg)
L1	EFB.L1.50.045.A	-	50	450	480	0	1	B13	207	175	190	190	14.5
L2	EFB.L2.63.060.A	-	63	600	630	0	1	B13	242	175	190	190	16.7
LB3	EFB.LB3.65.065.A	-	65	650	680	0	1	B13	278	175	175	175	17.9
L3	EFB.L3.72.072.A	-	72	720	750	0	1	B13	278	175	190	190	19.1
LB4	EFB.LB4.75.073.A	-	75	730	760	0	1	B13	315	175	175	175	20.7
L4	EFB.L4.84.080.A	-	84	800	850	0	1	B13	315	175	190	190	22.0
L5	EFB.L5.100.085.A	-	100	850	850	0	01	B13	353	175	190	190	23.6

AGM - STARTER BATTERIES

Box	Çelik Code	Part Number	Capacity at 20 Hr Rate (Ah)	CCA EN (A)	CCA SAE (A)	Layout	Terminal	Hold Down	Lenght (mm)	Width (mm)	Height Except Terminal (mm)	Height (mm)	Weight With Acid (kg)
L1	AGM.L1.50.056.A	-	50	560	560	0	1	B13	207	175	190	190	15.2
L2	AGM.L2.60.068.A	-	60	680	720	0	1	B13	242	175	190	190	18.0
L3	AGM.L3.70.076.A	-	70	760	800	0	1	B13	278	175	190	190	20.5
L4	AGM.L4.80.080.A	-	80	800	850	0	1	B13	315	175	190	190	23.5
L5	AGM.L5.95.090.A	-	95	900	950	0	1	B13	353	175	190	190	26.5

AUTOMOTIVE

EFB - JAPANESE (JIS) TYPE



EFB - EUROPEAN (DIN) TYPE

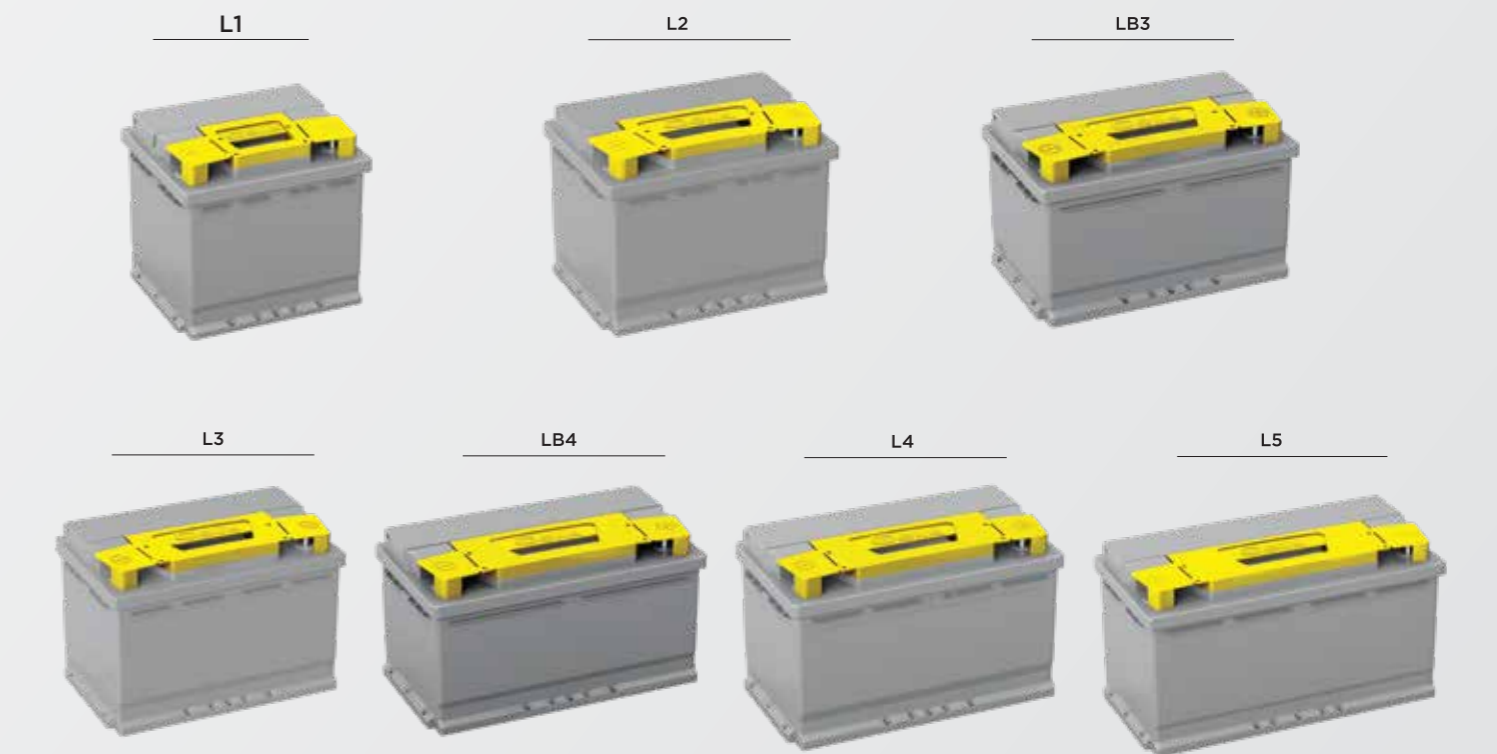

AGM



COMMERCIAL

COMMERCIAL

SFB SERIES 1 - HEAVY DUTY TYPE STARTER BATTERIES

Box	Çelik Code	Part Number	Capacity at 20 Hr Rate (Ah)	CCA EN (A)	CCA SAE (A)	Layout	Terminal	Hold Down	Lenght (mm)	Width (mm)	Height Except Terminal (mm)	Height (mm)	Weight With Acid (kg)
D26	D26.50.045.A	48D26L	50	450	480	0	1	B00	262	175	200	222	15.0
	D26.50.045.B	48D26R	50	450	480	1	1	B00	262	175	200	222	15.0
C13	C13.105.076.F	60512	105	760	800	0	1	B03	347	175	207	232	26.0
	C13.105.076.G	60513	105	760	800	1	1	B03	347	175	207	232	26.0
D2	D2.115.080.H	61527	115	800	850	0	1	B01	344	175	212	237	28.2
D3	D3.128.090.F	62810	128	900	950	0	1	B00	344	171	262	290	32.0
D4 (Type A)	1D4.120.080.A	62045	120	800	850	3	1	B03	513	189	195	223	33.5
	1D4.120.080.B	62046	120	800	850	3	1	B00	513	189	195	223	33.5
	1D4.135.080.A	63531	135	800	850	3	1	B03	513	189	195	223	35.0
	1D4.135.080.B	63533	135	800	850	3	1	B00	513	189	195	223	35.0
	1D4.135.095.A	63530	135	950	1000	3	1	B03	513	189	195	223	35.7
	1D4.135.095.B	63532	135	950	1000	3	1	B00	513	189	195	223	35.7
D5 (Type B)	1D5.150.100.A	65021	150	1000	1050	3	1	B03	513	223	195	223	40.5
	1D5.150.100.B	65022	150	1000	1050	3	1	B00	513	223	195	223	40.5
	1D5.165.110.A	66514	165	1100	1150	3	1	B03	513	223	195	223	43.2
	1D5.165.110.B	66515	165	1100	1150	3	1	B00	513	223	195	223	43.2
	1D5.180.120.A	68032	180	1200	1250	3	1	B03	513	223	195	223	46.5
	1D5.180.120.B	68033	180	1200	1250	3	1	B00	513	223	195	223	46.5
	1D5.190.125.A	69018	190	1250	1300	3	1	B03	513	223	195	223	47.5
	1D5.190.125.B	69021	190	1250	1300	3	1	B00	513	223	195	223	47.5
D6 (Type C)	1D6.200.125.B	70038	200	1250	1300	3	1	B00	518	273	216	242	55.5
	1D6.225.125.B	72538	225	1250	1300	3	1	B00	518	273	216	242	60.0
	1D6.225.140.B	72538	225	1400	1450	3	1	B00	518	273	216	242	60.5
	1D6.240.150.B	74012	240	1500	1600	3	1	B00	518	273	216	242	61.5

SFB SERIES 1

D26



C13



D2



D3



D4



Hold Down: B03



Hold Down: B00

D5



Hold Down: B03



Hold Down: B00

D6



SFB SERIES 1- SUPER HEAVY DUTY TYPE STARTER BATTERIES

Box	Çelik Code	Part Number	Capacity at 20 Hr Rate (Ah)	CCA EN (A)	CCA SAE (A)	Layout	Terminal	Hold Down	Lenght (mm)	Width (mm)	Height Except Terminal (mm)	Height (mm)	Weight With Acid (kg)
D4 (Type A)	1SD4.145.095.A	64535	145	950	1000	3	1	B03	513	189	195	223	38.0
	1SD4.145.095.B	64536	145	950	1000	3	1	B00	513	189	195	223	38.0
D5 (Type B)	1SD5.190.120.A	69019	190	1200	1300	3	1	B03	513	223	195	223	48.5
	1SD5.190.120.B	69020	190	1200	1300	3	1	B00	513	223	195	223	48.5
	1SD5.190.120.I	69026	190	1200	1300	4	1	B00	513	223	195	223	48.5
D6 (Type C)	1SD6.200.120.B	70039	200	1200	1250	3	1	B00	518	273	216	242	55.0
	1SD6.225.125.B	72539	225	1250	1300	3	1	B00	518	273	216	242	59.0
	1SD6.250.145.B	75011	250	1450	1500	3	1	B00	518	273	216	242	63.0

COMMERCIAL

SFB SERIES 2 - HEAVY DUTY TYPE STARTER BATTERIES

Box	Çelik Code	Part Number	Capacity at 20 Hr Rate (Ah)	CCA EN (A)	CCA SAE (A)	Layout	Terminal	Hold Down	Lenght (mm)	Width (mm)	Height Except Terminal (mm)	Height (mm)	Weight With Acid (kg)
C13	2C13.105.076.F	60527	105	760	800	0	1	B03	347	175	213	235	26.0
	2C13.105.076.G	60528	105	760	800	1	1	B03	347	175	213	235	26.0
D4 (Type A)	D4.120.080.A	62047	120	800	850	3	1	B03	513	189	195	223	33.5
	D4.120.080.B	62048	120	800	850	3	1	B00	513	189	195	223	33.5
	D4.135.095.A	63534	135	950	1000	3	1	B03	513	189	195	223	35.7
	D4.135.095.B	63535	135	950	1000	3	1	B00	513	189	195	223	35.7
D5 (Type B)	D5.150.100.A	65023	150	1000	1050	3	1	B03	513	223	195	223	40.5
	D5.150.100.B	65024	150	1000	1050	3	1	B00	513	223	195	223	40.5
	D5.165.110.A	66516	165	1100	1150	3	1	B03	513	223	195	223	43.2
	D5.165.110.B	66517	165	1100	1150	3	1	B00	513	223	195	223	43.2
	D5.170.110.A	67020	170	1100	1150	3	1	B03	513	223	195	223	43.5
	D5.170.110.B	67021	170	1100	1150	3	1	B00	513	223	195	223	43.5
	D5.180.120.A	68034	180	1200	1250	3	1	B03	513	223	195	223	46.5
	D5.180.120.B	68035	180	1200	1250	3	1	B00	513	223	195	223	46.5
	D5.190.125.A	69022	190	1250	1300	3	1	B03	513	223	195	223	47.5
	D5.190.125.B	69023	190	1250	1300	3	1	B00	513	223	195	223	47.5
D6 (Type C)	D6.200.125.B	70040	200	1250	1300	3	1	B00	518	273	216	242	55.5
	D6.225.125.B	72540	225	1250	1300	3	1	B00	518	273	216	242	60.0
	D6.225.140.B	72540	225	1400	1450	3	1	B00	518	273	216	242	60.5
	D6.240.150.B	74013	240	1500	1600	3	1	B00	518	273	216	242	61.5

SFB SERIES 2 - SPECIAL TYPE HEAVY DUTY STARTER BATTERIES

Box	Çelik Code	Part Number	Capacity at 20 Hr Rate (Ah)	CCA EN (A)	CCA SAE (A)	Layout	Terminal	Hold Down	Lenght (mm)	Width (mm)	Height Except Terminal (mm)	Height (mm)	Weight With Acid (kg)
GR31	GR31.105.076.D	-	105	760	800	9	1	B00	328	171	220	241	25.0
	GR31.105.076.E	-	105	760	800	9	8	B00	328	171	220	241	25.0
	GR31.105.090.D	-	105	900	950	9	1	B00	328	171	220	241	25.5
	GR31.105.090.E	-	105	900	950	9	8	B00	328	171	220	241	25.5

SFB SERIES 3 - SUPER HEAVY DUTY TYPE STARTER BATTERIES

Box	Çelik Code	Part Number	Capacity at 20 Hr Rate (Ah)	CCA EN (A)	CCA SAE (A)	Layout	Terminal	Hold Down	Lenght (mm)	Width (mm)	Height Except Terminal (mm)	Height (mm)	Weight With Acid (kg)
D4 (Type A)	SD4.145.095.A	64537	145	950	1000	3	1	B03	513	189	195	223	38.0
	SD4.145.095.B	64538	145	950	1000	3	1	B00	513	189	195	223	38.0
D5 (Type B)	SD5.190.120.A	69024	190	1200	1300	3	1	B03	513	223	195	223	48.5
	SD5.190.120.B	69025	190	1200	1300	3	1	B00	513	223	195	223	48.5
D6 (Type C)	SD6.200.120.B	70041	200	1200	1250	3	1	B00	518	273	216	242	55.0
	SD6.225.125.B	72541	225	1250	1300	3	1	B00	518	273	216	242	59.0
	SD6.250.145.B	75012	250	1450	1500	3	1	B00	518	273	216	242	63.0

COMMERCIAL

SFB SERIES 3 - SPECIAL TYPE SUPER HEAVY DUTY STARTER BATTERIES

Box	Çelik Code	Part Number	Capacity at 20 Hr Rate (Ah)	CCA EN (A)	CCA SAE (A)	Layout	Terminal	Hold Down	Lenght (mm)	Width (mm)	Height Except Terminal (mm)	Height (mm)	Weight With Acid (kg)
GR31	GR31.115.100.D	-	115	1000	1050	9	1	B00	328	171	220	241	26.5
	GR31.115.100.E	-	115	1000	1050	9	8	B00	328	171	220	241	26.5

SFB SERIES 2 & 3

C13



GR31



Terminal: 1

Terminal: 8

D4

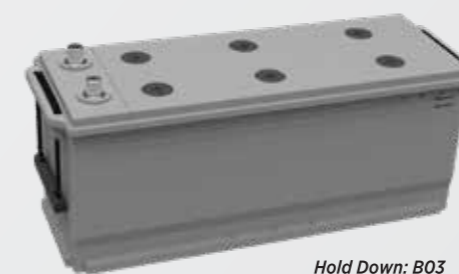

Hold Down: B03

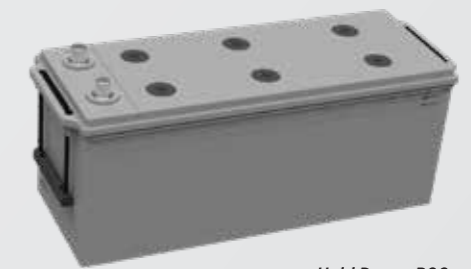

Hold Down: B00

D5



Hold Down: B03

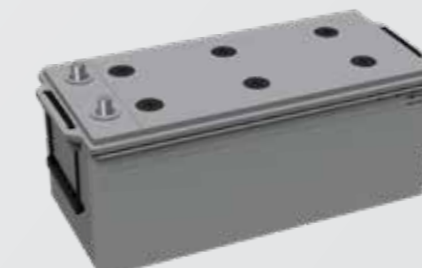

Hold Down: B00

D6



COMMERCIAL

EFB - STARTER BATTERIES

Box	Çelik Code	Part Number	Capacity at 20 Hr Rate (Ah)	CCA EN (A)	CCA SAE (A)	Layout	Terminal	Hold Down	Lenght (mm)	Width (mm)	Height Except Terminal (mm)	Height (mm)	Weight With Acid (kg)
D6	EFB.D6.240.125.B	-	240	1250	1300	3	1	B00	518	273	216	242	65.5

D6



SFB TAXI BATTERIES

Box	Çelik Code	Part Number	Capacity at 20 Hr Rate (Ah)	CCA EN (A)	CCA SAE (A)	Layout	Terminal	Hold Down	Lenght (mm)	Width (mm)	Height Except Terminal (mm)	Height (mm)	Weight With Acid (kg)
L2	TAXI.L2.65.054.A	-	65	540	570	0	1	B13	242	175	190	190	16.6
L3	TAXI.L3.72.057.C	-	72	570	600	0	1	B01	275	175	190	190	19.0

L2



L3



SFB - MILITARY PURPOSES BATTERIES

Box	Çelik Code	Part Number	Capacity at 20 Hr Rate (Ah)	CCA EN (A)	CCA SAE (A)	Layout	Terminal	Hold Down	Lenght (mm)	Width (mm)	Height Except Terminal (mm)	Height (mm)	Weight With Acid (kg)
D7	D7.100.072.C	-	100	720	750	2	1	B00	286	269	208	230	30.5
	D7.125.090.C	-	125	900	950	2	1	B00	286	269	208	230	36.5

AGM - MILITARY PURPOSES BATTERIES

Box	Çelik Code	Part Number	Capacity at 20 Hr Rate (Ah)	CCA EN (A)	CCA SAE (A)	Layout	Terminal	Hold Down	Lenght (mm)	Width (mm)	Height Except Terminal (mm)	Height (mm)	Weight With Acid (kg)
D7	AGM.D7.120.120.C	-	120	1200	1300	2	1	B00	286	270	208	230	39.5

D7

SFB



AGM



WE ARE FULL OF ENERGY
for your taxis to run smoothly



LEISURE

MARINE BATTERIES

Box	Çelik Code	Part Number	Capacity at 20 Hr Rate (Ah)	CCA EN (A)	CCA SAE (A)	Layout	Terminal	Hold Down	Lenght (mm)	Width (mm)	Height Except Terminal (mm)	Height (mm)	Weight With Acid (kg)
L5	ML5.90.060.A	-	90	600	650	0	1	B13	353	175	190	190	22.2
D3	MD3.125.090.A	-	125	900	950	0	1	B00	349	175	263	286	32.5
D5	MD5.180.100.A	-	180	1000	1050	3	1	B03	513	223	195	223	47.0
D6	MD6.200.100.B	-	200	1000	1050	3	1	B00	518	273	216	242	62.2

FULL ENERGY BATTERIES

Box	Çelik Code	Part Number	Capacity at 20 Hr Rate (Ah)	CCA EN (A)	CCA SAE (A)	Layout	Terminal	Hold Down	Lenght (mm)	Width (mm)	Height Except Terminal (mm)	Height (mm)	Weight With Acid (kg)
L1	FL1.48.030.A	-	48	300	320	0	1	B13	207	175	190	190	13.0
L2	FL2.60.036.A	-	60	360	380	0	1	B13	242	175	190	190	14.5
L3	FL3.75.048.A	-	75	480	500	0	1	B13	278	175	190	190	17.5
L5	FL5.95.064.A	-	95	640	660	0	1	B13	353	175	190	190	22.5
D31	FD31.100.064.A	-	100	640	660	0	1	B01	306	175	202	224	25.0
D4	FD4.135.068.A	-	135	680	750	3	1	B03	513	189	195	223	35.5
D5	FD5.165.095.A	-	165	950	1000	3	1	B03	513	223	195	223	42.5
D6	FD6.225.110.B	-	225	1100	1150	3	1	B00	518	273	215	242	56.5

GEL BATTERIES

Box	Çelik Code	Part Number	Capacity at 20 Hr Rate (Ah)	CCA EN (A)	CCA SAE (A)	Layout	Terminal	Hold Down	Lenght (mm)	Width (mm)	Height Except Terminal (mm)	Height (mm)	Weight With Acid (kg)
D6	GD6.200.085.B	-	200	850	900	3	1	B00	518	273	216	242	72.5
	GD6.230.090.B	-	230	900	950	3	1	B00	518	273	216	242	76.0

LIFESTYLE BATTERIES

Box	Çelik Code	Part Number	Capacity at 20 Hr Rate (Ah)	CCA EN (A)	CCA SAE (A)	Layout	Terminal	Hold Down	Lenght (mm)	Width (mm)	Height Except Terminal (mm)	Height (mm)	Weight With Acid (kg)
L5	LAGM.L5.95.090.A	-	95	900	950	0	1	B13	353	175	190	190	26.5
L5	LL5.100.070.A	-	100	700	750	0	1	B13	353	175	190	190	23.3
D31	LD31.90.064.D	-	90	640	700	1	1	B01	306	175	202	224	22.4
	LD31.100.070.D	-	100	700	750	1	1	B01	306	175	202	224	23.5
GR31	LGR31.115.075.D	-	115	750	800	9	1	B00	328	171	220	241	25.5
D26	LD26.70.045.B	-	70	450	500	1	1	B00	260	173	204	225	18
	LD26.80.054.B	-	80	540	600	1	1	B00	260	173	204	225	19

LEISURE

SFB - MARINE

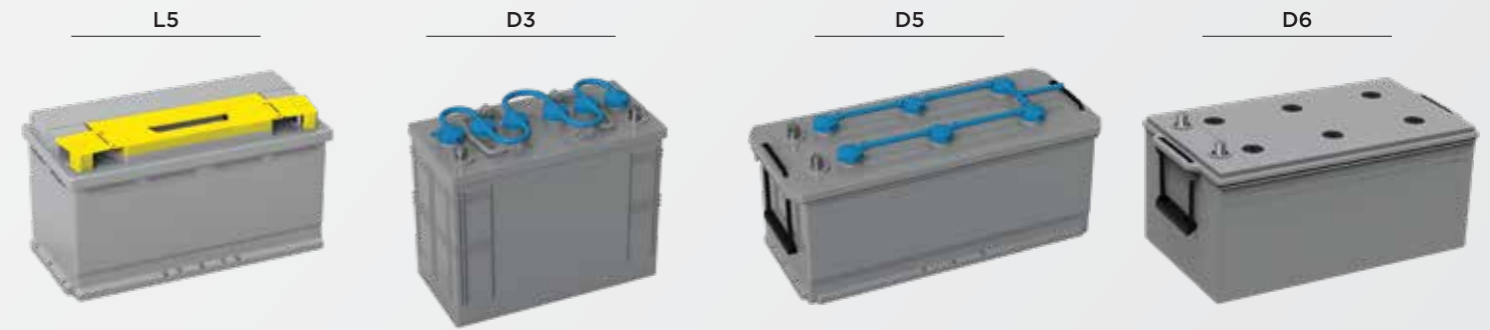

EFB - FULL ENERGY

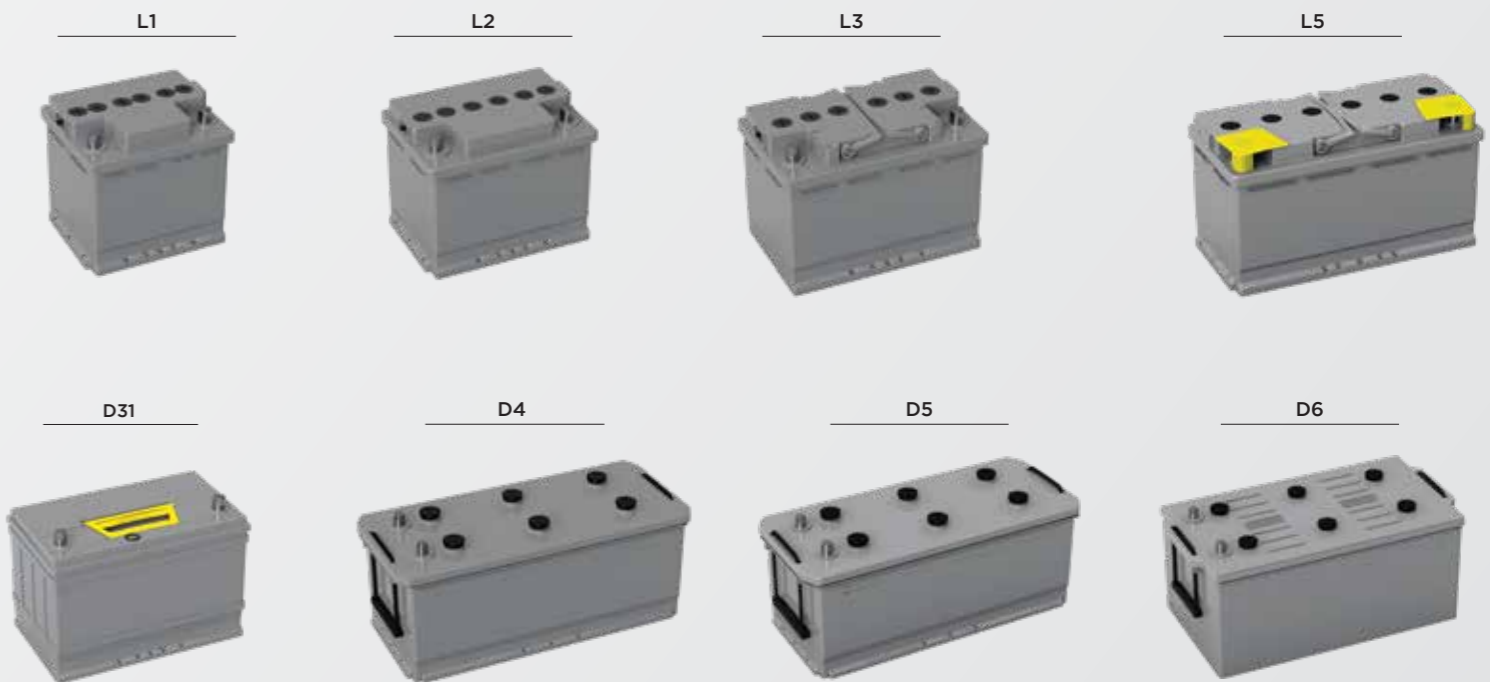

GEL

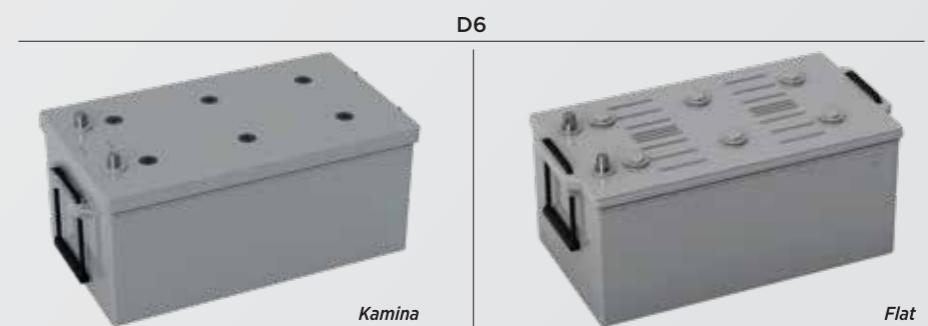

TECHNICAL DRAWINGS

**Durable
Battery**

LAYOUT

12 Volt

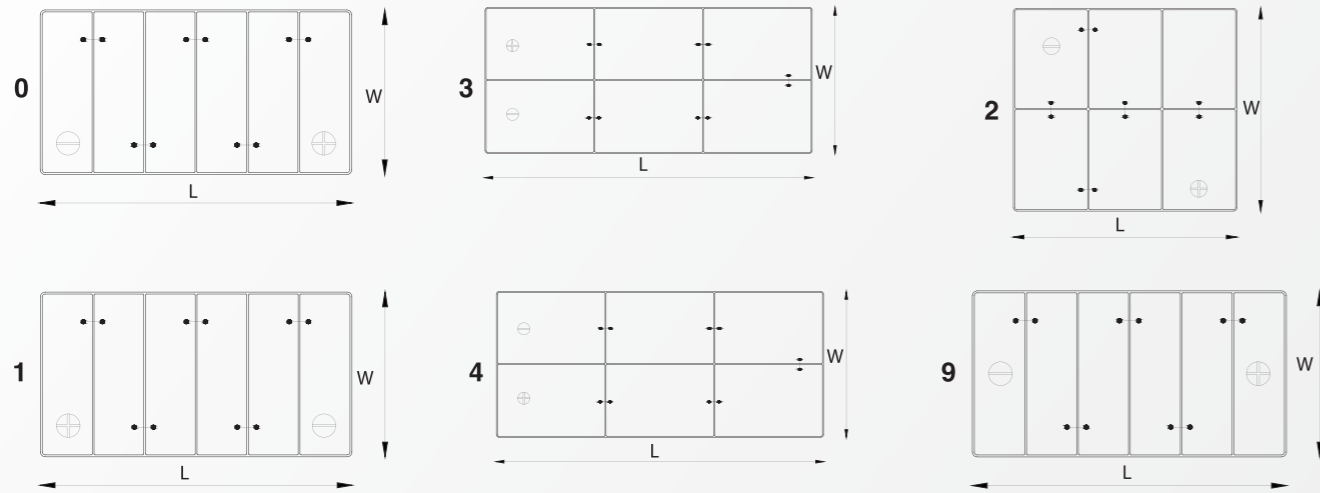

*W: Width, L: Length

TERMINAL

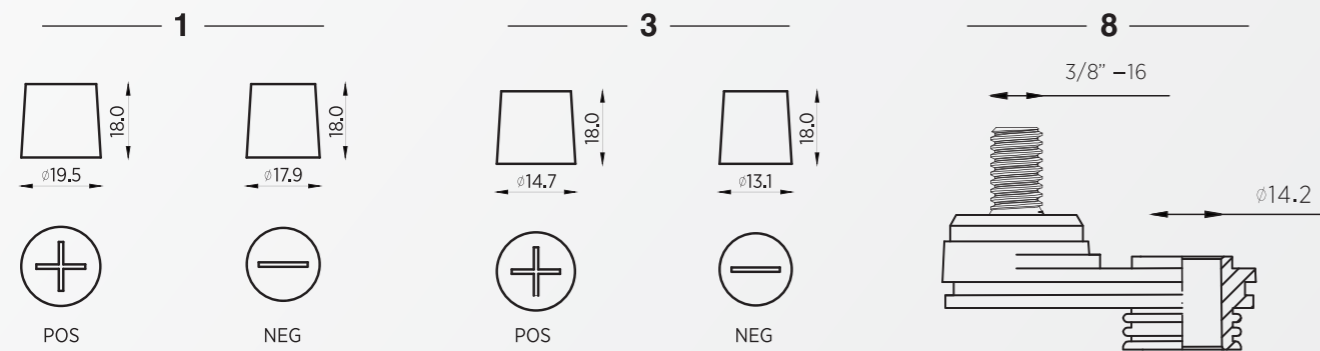

HOLD DOWN

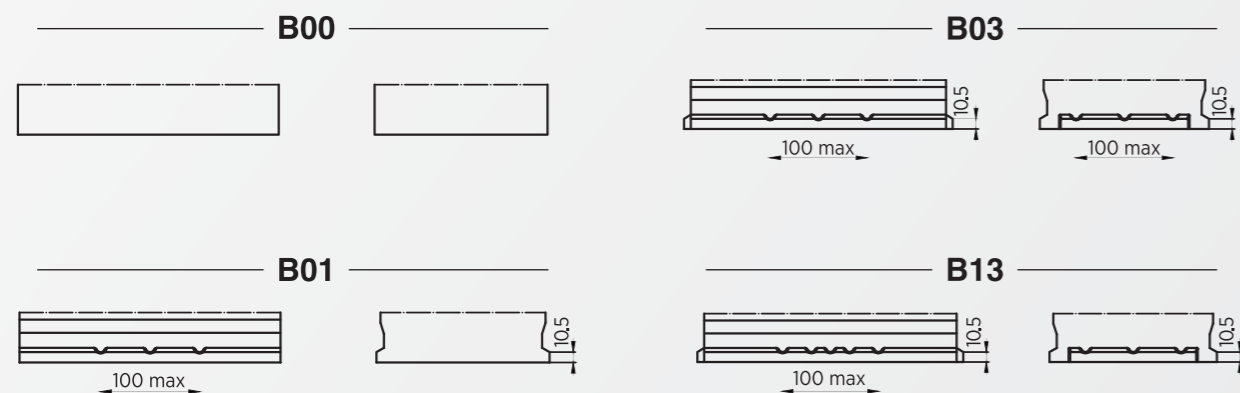

Celik[®]
battery